

THE FUTURE OF CAAD: FROM COMPUTER-AIDED DESIGN TO COMPUTER-AIDED COLLABORATION

Profesor Yehuda E. Kalay

Berkeley CAD Research Group

Departamento de Arquitectura

University of California at Berkeley

kalay@socrates.berkeley.edu

ABSTRACT

The primary uses of computers in the construction industry have been shifting, over the past four decades, from the evaluation of proposed design solutions, to their graphical (and other) representation, and more recently to facilitating collaboration among the various professionals who are involved in the design process. This paper argues that what may appear to be shifts in emphasis actually represents convergence on a single, original goal: the use of computers to help designers (and others who are involved in the design decision making process) to assess the quality, desirability, and the implications of their creations. Such assistance requires representation, communication, and analysis. The paper goes on to show how these individual parts can be joined into an integrated collaborative design environment, where they build upon and strengthen each other. Moreover, the paper argues that this convergence represents the future of CAAD research and development.

This argument is derived from the paradoxical state of the profession of engineering in general, and the construction industry in particular, where the design, construction and management of highly integrated facilities is undertaken by severely fragmented and temporarily assembled teams, comprising experts who represent a wide range of differing, sometimes conflicting agendas, worldviews, professional jargons, and methods of practice. They must collaborate, because the artifacts being designed have become too complex and must abide by too many requirements (technical, social, regulatory, financial, etc.) for any one professional to be able to handle them all by himself. But their collaboration is fraught with misunderstandings and attempts to improve individual parts at the expense of others, causing an overall diminished performance of both the design process and its products.

This paper argues that improving the overall quality of the products, and the process of their design, can only be accomplished when the heretofore separate solutions are considered together, as integral parts of an overall solution. The paper describes the efforts that have been made by the CAD Research Group in Berkeley over the past six years in developing an integrated collaborative design environment that can facilitate multidisciplinary, a-synchronous design of buildings. The environment includes several semantically-rich, shared product representations, a network of distributed evaluators, and graphically-enhanced collaboration and negotiation tools.

Key Words: *Collaborative design, distributed design environment, product modeling, performance modeling, process modeling, negotiation, integration.*

RESUMEN

Los usos principales de las computadoras en la industria de la construcción han ido cambiando, en las últimas cuatro décadas, de la evaluación de propuestas de diseño, a su representación gráfica (y de otras formas), y más recientemente a la facilitación de la colaboración entre los varios profesionales envueltos en el proceso de diseño. Este artículo plantea que lo que puede parecer ser cambios en el énfasis representan la convergencia hacia una sencilla y original meta: el uso de las computadoras para ayudar a los diseñadores (y otros profesionales envueltos en el proceso de toma de decisiones de diseño) a evaluar la calidad, deseabilidad, y las implicaciones de sus creaciones. Esta asistencia requiere representación, comunicación y análisis. El artículo muestra como estas partes individuales pueden unirse formando un ambiente de diseño colaborativo integrado, donde crecen y se refuerzan unas a otras. Además, se discute que esta convergencia representa el futuro de la investigación y desarrollo del CAAD.

Esta discusión se deriva del estado paradójico de la profesión de la Ingeniería en general, y la industria de la construcción en particular, donde el diseño, la construcción y la gestión de edificaciones altamente integradas es emprendido por grupos severamente fragmentados y reunidos temporalmente, que incluyen expertos que representan un amplio rango de diferentes, y a veces conflictivas agendas, puntos de vista, jergas profesionales, y métodos de práctica. Éstos deben colaborar, porque los artefactos que se diseñan se han vuelto demasiado complejos y deben cumplir con muchos requerimientos (técnicos, sociales, reguladores, financieros, etc.) para que cada uno de los profesionales los pueda manejar por sí solo. Pero su colaboración está cargada de malentendidos e intentos de mejorar partes individuales a expensas de otras, causando un desenvolvimiento global reducido tanto en el proceso de diseño como en sus productos.

Se sostiene que la mejora de la calidad global de los productos, y el proceso de diseñarlos, sólo puede ser obtenida cuando las hasta ahora soluciones separadas sean consideradas a la vez, como partes integrales de una solución global. Se describe los esfuerzos realizados por el Grupo de Investigación en CAD en Berkeley en los últimos seis años para desarrollar un ambiente integrado de diseño colaborativo que pueda facilitar el diseño de edificaciones multidisciplinario y asincrónico. Este ambiente incluye varias representaciones de productos compartidas y ricas semánticamente, una red de evaluadores distribuidos, y herramientas de colaboración y negociación mejoradas en su aspecto gráfico.

Palabras clave: *Diseño colaborativo, ambientes distribuidos de diseño, modelado de productos, modelado de funcionamiento, modelado de procesos, negociación, integración.*

The changing role(s) of caad

Horst Rittel defined design as “*an activity aimed at achieving certain desired goals without undesired side- and after-effects*” [Rittel & Webber 1984]. He also called architectural design problems “wicked.” because one cannot achieve all the desired goals (they might be in conflict with each other), nor can one avoid causing undesired side- and after-effects (either by action or no action). A ‘good’ design, accordingly, is one that achieves as many of the desired goals as possible, while causing the least number of undesirable side- and after effects.

But how can one achieve such a ‘good’ design? How can one tell if a certain design proposal will achieve a reasonable set of goals? How can one tell what undesirable side- and after-effects will it have? Such assessment requires foresight, judgement, and—most of all—considerable knowledge about the many diverse affects a design proposal might have. The more complex the design, the harder it is to predict and evaluate its ‘goodness.’

CAAD was introduced in the 1950s to assist designers in assessing the ‘goodness’ of their creations. Initially, computers were used to assist in engineering analyses. The process of designing buildings continued to use habitual, manual methods, but at certain points along the design process quantities were taken off manually and fed into computer programs that could analyze them. The results were then applied manually to the evolving design [Mitchell 1977].

This process soon bogged down, when the difficulties associated with the input/output bottleneck outstripped the benefits that could be derived from the evaluations. The emphasis in CAAD research shifted from developing better engineering analysis programs to finding more efficient modes for bringing the emerging design solution to the computer: computational representation of buildings took center stage.

Computer graphics were first introduced in the late 1940s, through the US Navy’s Whirlwind project (a general purpose flight simulator). But their application to (mechanical) design only occurred at MIT in the 1960s, through the efforts of Steven Coons and Ivan Sutherland, who developed Sketchpad, the first interactive 2D and 3D design tool. This approach simplified the input of design properties into analyses programs, which opened the floodgate for the development of CAD programs. A bumper-crop of such programs was introduced in the 1970s, and became a popular design tool in the 1980s. Research into representing information other than graphics soon followed.

Along the way, some attempts were made to use computers as design generators [Armour & Buffa 1968, Cross 1977]. These attempts have, by and large, failed to provide meaningful assistance to designers. Not only were the solutions generated by these program rather trivial, they also intruded on what designers considered their most ‘sacred turf.’ Such objections were not raised with regard to computer-aided evaluation, representation, and communication, where in most cases computer assistance was welcomed.

But drafting and modeling systems could meet only a few of the original needs, namely—visual appraisal of the emerg-

ing design solutions, and certain geometry-based evaluations (e.g., habitability) [Kalay & Shaviv 1979]. Hence, researchers resumed their quest for more powerful computer-aided evaluation programs, and better means for representing non-geometric building information [Steinfeld & Kalay 1990]. In the 1980s this search was strongly influenced by the general euphoria associated with Expert Systems [Flemming 1994]. A large number of expert and other knowledge-based systems were developed, purporting to package design expertise and to bring it to bear on the design process without the experts who generated the knowledge in the first place [Carrara et al 1994, Coyne et al 1990]. Few of these systems lived-up to their expectations, and it soon became obvious that the real meaning of ‘Expert Systems’ was “systems for the use by the experts themselves” [Shaviv et al 1996].

The globalization of the building industry in the 1990s, coupled with the increasing capabilities of computers as telecommunication devices due largely to the rise of the Internet, brought about the birth of computer-aided collaboration. The first use of computers as facilitators of collaboration was purely technical: it was easier and faster to send digital design information through the Internet than physical drawings through the mail. But this ability, along with accelerated design/build schedules, raised serious problems of concurrency, authority, and version control. Some systems that can manage the multifarious data formats used in a typical building project have emerged, such as ProjectNet by BlueLine/OnLine and Speedicon (a German company). Still, these systems are, at best, project management tools, not collaboration tools: they facilitate the sharing of *information*, not the sharing of *understanding*, which is a necessary condition for joint efforts in design.

What do we mean by ‘shared-understanding’? Why is it necessary? How can it be facilitated by CAAD? These are the questions this paper tries to answer.

What is collaboration?

In his seminal book *The Sciences of the Artificial*, Herbert Simon argued that any body of knowledge that requires more than 10 years to master tends to fragment into specializations [Simon 1969]. Such fragmentation has occurred in medicine, law, engineering, as well as in the design of buildings. But while in other disciplines the specialist can typically deliver the service independently from other specialists, a specialist in the building industry represents only one part of an integral whole: he can rarely complete the task on his own. At the same time, the task itself cannot be completed without the contributions of the specialists. Thus, the fragmentation of knowledge in the building industry has created a *symmetry of ignorance*, where no single professional has all the knowledge needed to design a complex facility, and where it is no longer possible to design a building without consulting many specialists (architects, engineers, construction managers, lighting consultants, mechanical engineers, acoustical experts, financial advisors, and legal experts, etc.) [Cuff 1991].

Collaboration can be defined as “*the agreement among*

specialists to share their abilities in a particular process, to achieve the larger objectives of the project as a whole, as defined by a client, a community, or society at large" [Hobbs 1996]. By combining their abilities, a collaborative arrangement can help individuals undertake larger and more complex tasks, gain perspective on the shared enterprise they would not have been able to perceive on their own, learn from others, and be motivated by them. Collaboration, as such, is an enabling force. At the same time, it can also be a restrictive force, in the sense that the action best suited for the goals and needs of one individual may not also be best suited for the goals of another collaborator, thereby raising potential conflicts and the need to compromise or even to yield to the needs of others.

Collaboration, therefore, is a highly complex and challenging task. It has been the subject of study in virtually every field: sociology, psychology, politics, science, technology, and professional practices in law, medicine, and engineering. Yet, collaboration in A/E/C (Architecture, Engineering, Construction) is different from collaboration in other fields. First, it involves individuals representing often fundamentally different professions, who hold different goals, objectives, and even beliefs. Unlike collaborators in medicine or in jurisprudence, who share a common educational basis, architects, structural engineers, electrical engineers, clients, property managers, and others who comprise a design team, rarely share a common educational foundation, and often have very different views of what is important and what is not. Second, it involves what has been termed 'temporary multi-organizations': a team of independent organizations who join forces to accomplish a specific, relatively short-term project. While they work together to achieve the common goals of the project, each organization also has its own, long-term goals, which might be in conflict with some of the goals of the particular project, thereby introducing issues that are extraneous to the domain of collaboration [Mohsini 1992]. Third, collaboration in A/E/C tends to stretch out over a prolonged time, even when the original participants are no longer involved, but their decisions and action still impact the project [Jockusch 1992].

Communication vs. shared-understanding

Communication is a prerequisite to (intentional) collaboration: it is the means by which the intents, goals, and actions of each one of the participants are made known to the other participants in the collaborative effort, thereby forming the basis for their own actions. Communication, however, is not enough: the heterogeneous backgrounds of the participating professionals in the A/E/C industry are often a source for misunderstandings and misinterpretations of the communicated information, leading to errors and conflicts. Although better means of communication have been developed over the past 500 years, in the form of drawings, three-dimensional models, and written specification, they have not overcome the problem of shared-understanding.

Misunderstanding in A/E/C

In their book *The Social Construction of Reality*, Berger and Luckmann [1967] discuss the processes by which any body of knowledge comes to be accepted and recognized as reality.

They argue that 'reality' is not an objective, value-less, fixed phenomenon, shared by everyone. Rather, it is a product of *social systems* through which human knowledge is developed, transmitted and maintained. It is, in many ways, a matter of *belief*.

As such, there is no shared, objective basis for the design and evaluation of buildings (or any other product, for that matter). The importance, meaning, and value of objects, concepts, and situations can only be understood within the socially constructed reality within which they are perceived. This reality, or 'worldview,' is different for each one of the participants in the process of designing, constructing, and using buildings. It is developed through professional education and practice—the process of socializing into a specific way of thinking and acting. Professional education teaches a 'right' way of seeing the world, and instills faith in that way, which over time becomes no longer open to challenge. Each worldview may have at its core a different set of values, or objectives, which might not be central to other worldviews, or may be completely absent from their view, as depicted schematically in Figure 1. Architects, engineers, construction managers, facilities managers, building owners, and end-users all have different worldviews, making it difficult for each to understand and to value the joint product in the same way as other participants do. While this is one of the virtues of the collaborative process, ensuring that no legitimate view is overlooked, it is also one of its most critical impediments.

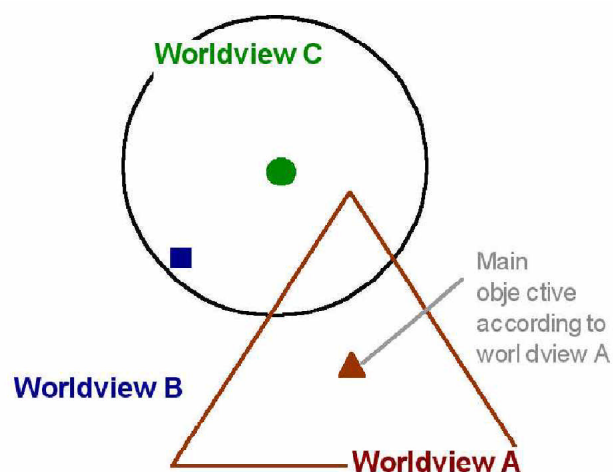

Figure 1: Different worldviews promote different objectives.

Conditions for collaboration

Given that all the participants in a building enterprise have been educated into their own ways of seeing, understanding, and valuing the world, it is inevitable that there will be conflicts between their different socially constructed realities. The first step in resolving such conflicts and facilitating joint action is to recognize that different worldviews exist. The second step is to develop means that can help each participant at least to understand, if not to agree with the worldviews of the other participants. Only then can they arrive at the third step: the development of a consensual worldview that will recognize the legitimate con-

cerns and goals of each participant and maximize the overall utility of the project (what Kuhn [1962] called 'super paradigm').

That different worldviews exist is self-evident, though not always recognized by the participants in the collaborative process. *Understanding* these different worldviews, as the second step in developing joint action, is not so obvious. For collaboration in design is not a matter of mere *coordination* of the inputs of the specialists who join together for the purposes of the project. Rather, it is a matter of *joint decision making*, which will deliver a better overall product. Such collaboration is much more difficult to accomplish than mere coordination, especially in a field such as A/E/C, because it requires an initial *suspension of judgment* by the participating professionals [Shibley & Schneekloth 1988]. But design professionals are trained to evaluate and to judge, and immediately to seek the action that follows from their observations, while discarding information that appears to be irrelevant. They are trained to search for congruence between what they observe and the theoretical constructs of their respective professional worldviews, which they have come to accept as truth. Professionally, neither architects, nor engineers nor construction managers are rewarded for suspending judgment or for allowing other worldviews to alter their own. The suspension of judgement increases the professional's vulnerability and the risk of failure. It can only be justified if the risks taken lead to the attainment of desirable objectives.

How to collaborate?

Much effort has been put into the facilitating *communication* among the participants in a construction project and, paradoxically, into resolving conflicts among the professionals once they arise [Axelrod 1984, 1997, Protzen & Dehlinger 1972, Pruitt 1981, Raiffa 1982, Sycara 1988, etc.]. Much less effort has been put into promoting *shared-understanding*, which is the source of the conflicts.

Professional practices in A/E/C have recognized the need for collaboration, and have generally adopted one of two methods to facilitate it: *hierarchically-partitioned* decision making or *temporally-partitioned* responsibilities.

Hierarchically-partitioned decision making among the professionals comprising an A/E/C team takes the form of contractual arrangements, where one of the participants (often the architect) is appointed team-leader, and the rest are considered sub-contractors or consultants [Mohsini 1992]. While this arrangement may be efficient in terms of process (i.e., getting the job done), it introduces the risk of diminishing the overall performance of the product by reducing the commitment of the sub-contractors to the project because of their diminished ownership or influence on the product (hence the well-known syndrome of sub-contractors 'designing for the minimum,' rather than 'designing for the maximum'). The overall result, therefore, is often less than optimal.

Temporally-partitioned responsibilities represent the typical 'over the wall' practice of transferring responsibility for the project from one design professional to the next, as it moves through the design/build/use process. Thus, the responsibilities of the architect end when construction begins, and the construc-

tion manager's responsibilities end when the facilities manager takes over. While this method too is efficient in terms of process (and in terms of legal exposure), it is detrimental in terms of quality: the carefully considered knowledge which has been applied in earlier design phases is lost when the responsibilities are transferred, along with all the assumptions underlying them [Hitchcock 1996].

Thus, accepting either one of these two collaboration strategies, while superficially efficient, may result in overall failure of the project or, at best, less than optimal overall performance: the piecemeal nature of hierarchically- or temporally-partitioned decision making in habitual collaboration methods, makes it almost impossible to recognize the existence of higher-level objectives, let alone develop a combined, overall view of the project. Hence, these approaches can be seen as methods of *coordination*, rather than *collaboration*.

Several computational methods, aimed at facilitating network-like (rather than piecemeal) collaboration in A/E/C have been proposed by researchers in CAAD. Their objectives have generally been to assist human designers to *communicate* and to *evaluate* the evolving product in an effective, and if possible, concurrent manner. The methods and tools that were developed for these purposes can be classified as *product-sharing* methods, *performance-evaluation* methods, and *process-oriented* methods.

Product-sharing methods

These methods use some common data exchange format to facilitate the communication among the participating professionals. Efforts such as ID'EST, EDM, and COMBINE [Kim et al 1997, Eastman & Siabiris 1995, Augenbroe 1995, Amor et al 1995] have focused on developing sharable product models and databases of increasing sophistication that include factual information about the objects they describe, with particular emphasis on solving issues of concurrency, data-integrity, and data-sharing [Eastman 1994, Galle 1995, Jacobsen et al 1997, Sun & Lockley 1997, Yaski 1981]. Most of these methods assume that the data will be accessed by suitable computer programs. Some, like FCDA [Khedro et al 1993], assume that the data will be processed by human experts. An underlying assumption in all these systems is, nonetheless, that the *readers* of the data (whether human or computer programs) will interpret it correctly, using their own professional knowledge. However, Valkenburg [1998] proved this assumption to be false, because of the social and professional reasons discussed earlier. Therefore, while these efforts have made *communication* easier and more efficient, they have not, in and of themselves, improved *shared-understanding*, which is fundamental for making joint decisions and for negotiating tradeoffs among competing objectives.

Performance-evaluation methods

These methods combine individual, discipline-specific performance evaluations into a composite or an overall performance assessment of the evolving design solution, such as demonstrated by Wiezel & Becker [1992], and by Hacfoort & Veldhuisen [1992]. To arrive at an 'overall' assessment, some of these methods require setting up a weighted goal tree, stating the relative importance (according to someone's worldview) of individual

design criteria [Manning & Mattar 1992]. Typically, such weighting systems must be set up prior to engaging in the design process, and cannot respond to changes in preferences arising from the dynamically unfolding design process. An alternative to relative weighting is the use of *benchmarks*, developed from case studies, as demonstrated by the BDA system [Papamichael et al 1998]. Case-based methods are very sensitive to the context of the project they come from. Systems that can account for the context of the case study are emerging, though they are yet to be integrated with collaboration methods. Generally, performance-based systems tend to emphasize the *technological* aspects of the evolving design solution (energy, lighting, cost, etc.), while largely ignoring the *human* aspects of design collaboration. They suffer, therefore, from the same limitations as the habitual collaboration methods, namely—compartmentalization of worldviews and a tendency to communicate the *results* of the evaluations without the *objectives* they strive to accomplish, or the *assumptions* they rely upon.

Process-oriented methods

These methods emphasize the deliberative aspects of design decision making processes, in terms of design *intents*, *assumptions* and *arguments* in favor of or against proposed design actions. This mode of collaboration, first suggested by Musso & Rittel [1967], was implemented in case- and knowledge-based networked hypermedia systems, such as MIKROPLIS, PHIDIAS I and II, and Janus [McCall 1986, McCall et al 1990, 1994]. Agent-based systems that support argumentation were developed by Pohl and Myers [1994], and implemented in their ICADS system. These systems have helped us understand the deliberative nature of the design process, but suffer from the inherent difficulty of encoding design knowledge in computational constructs, such as expert systems and agents. Therefore, they tend to work well in restricted domains, such as military ship load planning in the case of ICADS, or NASA's lunar habitat module, as demonstrated by PHIDIAS II.

P3: An integrated collaborative design environment

Each of the approaches listed above has certain advantages, as well as drawbacks, with respect to its ability to facilitate shared-understanding across disciplinary boundaries. The approach we propose is, essentially, a judicious *collection* and *composition* of several previously proposed approaches, with many adaptations and enhancements. It is their collection and specific composition that endows our approach with what we believe is needed to enhance multidisciplinary shared-understanding.

The integrated collaborative design environment we are developing, which we call P3 [Kalay 1998], consists of three complementary computational constructs:

1. Semantically-rich *representational* tools, which provide explicit reference and frame-of-reference representations for the objects comprising the evolving design solution.
2. *Communication* and *evaluation* tools, through which the values, issues, and assumptions of each one of the participants are made known to the other participants.

3. *Negotiation* tools, which help the participants adjust their respective solutions and objectives for the purpose of improving the overall performance of the project.

We have begun to implement such an integrated, distributed design environment, to support the design phase of buildings. In the following we will describe each of these constructs, and how they come together into one whole.

Representation tools

The purpose of these tools is to enable the sharing of project information (about the facility and its context) among the participating professionals. In contrast to most existing CAD tools, we have embedded a considerable amount of *semantic knowledge* in the shared information, including high-level intents, beliefs, and as much as possible, disciplinary conventions regarding the represented objects. This added semantic information augments the factual information carried by the shared product model, without which the subsequent interpretation, evaluation and negotiation processes cannot work. By providing shared semantic information we can reduce the amount of interpretation that needs to be made by each one of the collaborating experts, or at least make their individual interpretations more consistent with each other. For example, when communicating door information, we include architectonic notions such as its affordance of *passage* and *privacy*, in addition to typical product-related properties such as *material*, *cost* and *fire rating* attributes.

Our approach to embedding semantics in the product model separates assembly-related information (mainly, the topology of the product) from object-related information (its attributes), and from context-related information. This separation, which is reflected in the three different databases discussed below, allows each to be optimized to meet its own objectives. Together, they provide complete product and context information.

Object database

The Object Database (ODB) represents *referent* information [Cohen 1944]: information that defines the nature and the character of the object, and the conditions under which this character will be altered. This information is object-specific but project-independent; that is, it is specific to an object, regardless of its frame-of-reference. Thus, the ODB can be considered a semantically-rich *digital library* and *dictionary* of objects (e.g., walls, doors, windows, etc.). We use an inheritance hierarchy to structure the information in a non-redundant form, as depicted in Figure 2.

By definition, each level of the inheritance hierarchy includes more specific information than its parent level. This information comprises both *descriptive* data (e.g., the object's name, shape, materials, and other attributes), and *behavioral* data (e.g., that a door affords access, egress, etc.), as depicted in Figure 3. General integrity constraints, which define the conditions under which the nature of the object will change, are also included. Episodic information, in the form of design cases or manufacturers' catalogs (in multimedia form), provide anecdotal

information about the object. The intent of the ODB is to be comprehensive enough so professionals who may not be intimately familiar with the type of objects its represents will be able to learn about it without having to make implicit assumptions.

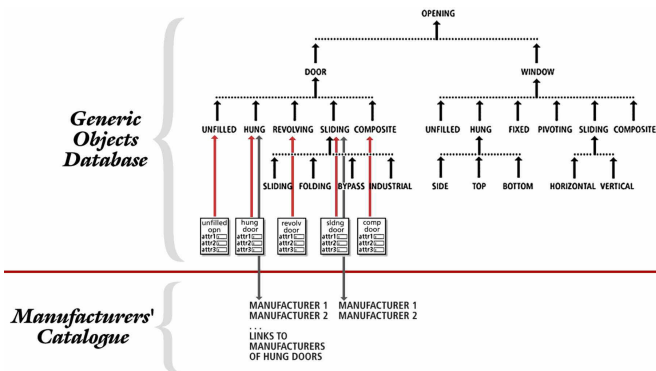

Figure 2: The inheritance hierarchy of DOORS (source: Timerman 1998).

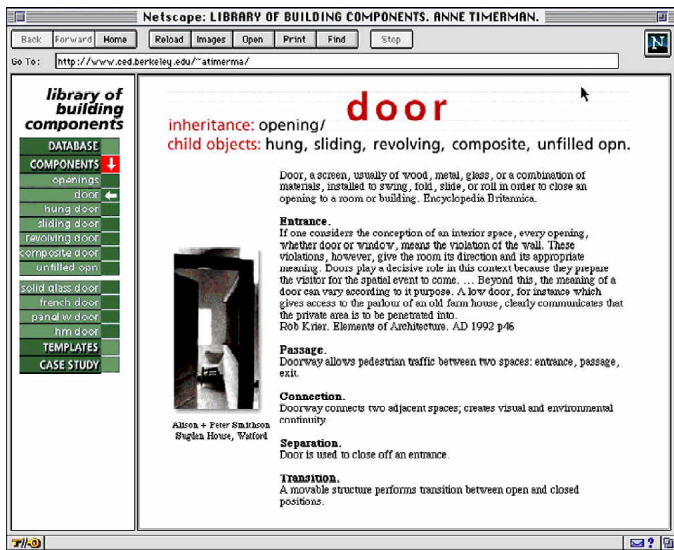

Figure 3: Door as a Generic object (source: Timerman 1998).

We have developed, so far, ODBs for DOORS and for WALLS, each of which is a collection of databases accessible through the World Wide Web [Timerman 1998, Kalay et al 1998]. These are based on the SfB classification system, which was developed in Sweden and is broadly used in most European countries, especially in Great Britain, to classify building-related objects. Its adoption provided us with a standard classification system, and introduced uniformity into the database (e.g., the number of levels from general to specific objects). As such, it provided a good starting point for composing and extending the Object Database, and saved us the considerable effort needed to develop a classification system of our own.

Project database

The Project Database (PDB) represents part of the *frame-of-reference* in which particular design objects are embedded (the other part of the frame-of-reference information is represented

by the Context Database). More specifically, the PDB includes *assembly* information (information about the relationships between an object, e.g. a door, and other objects, e.g. walls), as well as information that objects acquire when they are embedded in a particular project (e.g., dimensions, orientations, etc.). The PDB objects are linked to the ODB objects through an *instantiation* relationship, whereby they acquire the pertinent object-specific semantic information.

The specific representational model we have adopted for the PDB accommodates both structural and spatial views of the building, while facilitating a highly compact, yet well-formed, general, and complete representation of all the elements (Figure 4). The PDB can thus be viewed as an *architectural* assembly of spaces and the partitions between them, or as a *structural* assembly of walls, columns, and beams, with the spaces they bound. Given that the underlying components are shared between the two views, it is possible to identify elements in one view that may pose conflicts with the other view. For example, if a specific WALL has been designated as a shear wall in the structural view, then this information persists when the same wall is visited from the architectural view. If the shear-resisting capability has been designated as dominant, it will prevent the substitution of this wall with a non-shear resisting partition, such as a window-wall or a row of columns. This property of the representation thus accommodates changing referents and frames-of-reference, which is important when multi-disciplinary design is concerned.

Moreover, the links between the PDB objects are themselves semantically rich: they carry logical information regarding the *nature* of the link between objects (e.g., embeddedness, support, abutment, etc.). Therefore, they provide a conduit through which changes can be propagated: for example, if a WALL has been relocated, the doors and windows it contains will also be relocated. If the WALL has been replaced by a row of columns, the doors and the windows will be eliminated (or a message will be sent to the designer informing him of the consequences of the proposed change).

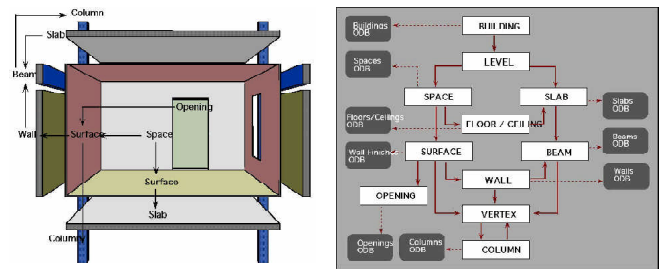

Figure 4: The architectural and structural views afforded by the PDB.

We are currently working on the third version of a non-redundant representation for the PDB, which includes both structural and spatial building elements, using a data structure modeled after the well-known *winged-edge* model [Khemlani et al 1998]. It facilitates a highly compact yet well-formed, general,

and complete representation of all the building elements associated with a facility (e.g., walls, floors, openings, beams, columns, etc.), along with all the topological interconnections between them.

Context database

The Context Database (CDB) represents information about the physical and temporal context of the project. Context is understood in its broadest sense: information the design team must respond to, and over which it has little or no control (e.g., topography, climate, views, cultural environment, economic and political environment, zoning codes, etc.). The context also comprises the predominant *activities* that the building must support, as implied by the nature of the project (e.g., medical procedures for treating patients in a hospital, the method of teaching in a school, and traditional habits of a family within its own house). As such, the CDB represents another facet of the frame-of-reference information.

We have only begun to develop the conceptual framework for the CDB, relying on principles borrowed from Geographical Information Systems (GIS), therefore it is not discussed here.

Communication and evaluation tools

Performance evaluation is very much discipline-specific. Over the past 30 years, many discipline-specific knowledge repositories, and their attendant tools (algorithms, expert systems, case-bases, etc.) have been developed. Many of these systems require their own form of input, and produce output that is often meaningful only to experts in their respective fields. It is impractical to re-design these systems, which represent considerable accumulation of knowledge and hard work (what is affectionately known as 'legacy' systems). Instead, we advocate *networking* existing evaluation systems to the collaboration environment through custom-made communication modules, which we call IDEAs (Intelligent Design Assistants). For example, an IDEa that connects an *energy expert* to the network is able to search the ODB, PDB, and CDB for the information needed to perform a thermal evaluation. It can also *translate* this shared data into the format used by a particular energy evaluation program. The (human) expert who uses the energy evaluation program can further augment the data with the necessary disciplinary information, and select appropriate defaults for the control parameters. Once the analysis has been completed, the (human) energy expert interprets and sums up the results in the form of a report, which she communicates (through the IDEa) to the other participants in the design process. The IDEa posts the report on a shared blackboard, and alerts interested individuals that it has been posted. Such an energy-expert IDEa has been recently completed [Benne 1998]. It connects the collaboration environment to ENERGY—a passive solar energy analysis program developed by Shaviv & Shaviv [1977].

In addition to the Energy analysis IDEa, we have completed the development of a Habitability analysis IDEa, and an IDEa that can evaluate the suitability of a dwelling to the Korean traditional lifestyle [Khemlani & Kalay 1997]. We have begun to develop IDEAs to evaluate the performance of windows

[Llavaneras 1996], and a Structural analysis IDEa.

Negotiation tools

Typically, the level of performance of the same design solution will be valued differently by the different professionals, due to their differing worldviews and objectives. To achieve the desired shared-understanding among the professionals it is necessary to communicate the results of the disciplinary valuations among the experts, in a manner that will be readily understandable by all of them. Furthermore, the communication must convey not only the *parametric value* of the performance (e.g., cost, energy use, etc.), but also the *degree of satisfaction* in which each professional views the results (i.e., his *valuation* of the results), and the *degree of flexibility* with which the performance may vary before that degree of satisfaction is greatly affected.

The method we have chosen to use for this purpose is based on the concept of *Satisfaction Functions*, first introduced by Musso & Rittel [1967], and more recently applied by Mahdavi et al as part of their SEMPER system [Mahdavi et al 1997, Mahdavi & Suter 1998]. These are mappings that express, in functional form, the perceived relationship between some *parameter value*, indicating the performance of a system (as predicted by some performance evaluation tool, or personally by the expert) and the subjective measure of its *desirability* under specific circumstances. Figure 5 depicts some typical satisfaction curves: the horizontal axis indicates the parameter value representing the performance of some aspects of the designed system (e.g., energy consumption, cost, etc.). The vertical axis measures the degree of satisfaction each performance value elicits.

Each satisfaction curve must, of course, be set by the respective expert, because each one reflects disciplinary knowledge, such as satisfaction thresholds and sensitivity to change. The sources of such knowledge might be prevailing practices, case studies, codes or standards, results of post-occupancy studies, individual priorities of the experts or their clients, etc. For instance, a function depicting the cost of construction per square foot of similar facilities may be used by the financial analyst or construction manager to convey his degree of satisfaction from the specific project's expected cost, thereby providing a disciplinary context for the valuation. These are *unary* functions, in the sense that each curve represents satisfaction derived from one performance characteristic only. This makes it possible to set them independently from each other, which greatly facilitates their use in the proposed collaborative environment.

Using these curves, it is possible to identify needs that are not being satisfied, and those that are being over-satisfied. A design solution can thus be sought that better achieves the under-satisfied needs, while achieving less-well the over-satisfied needs. The negotiation tools comprise the *Project Manager* (PM) module of the P3 system. They will consist, when fully implemented, of a blackboard displaying these satisfaction curves, means to identify possible tradeoffs among them (and alert the respective experts), and a threaded discussion tool to record the negotiations process.

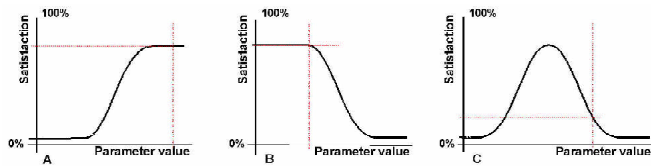

Figure 5: Typical satisfaction curves. The dotted lines represent how the current design solution performs, as viewed from different disciplinary points of view (A,B, and C), and how satisfactory that performance is.

The overall P3 environment

Figure 6 depicts, schematically, the overall distributed collaborative design environment. As the lighter shaded area illustrates, the various databases and the Project Manager(s) reside on, or are accessible through the World Wide Web. The disciplinary knowledge repositories and their respective IDEAs reside with the participating experts. Figure 6 also shows that several projects can share ODBs, which act as digital object libraries.

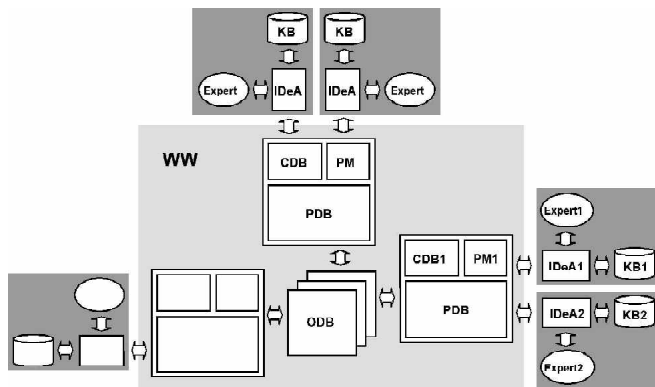

Figure 6: The overall schema of the distributed collaborative design environment.

Summary and conclusions

As we approach the end of the 1990s it is becoming more and more obvious that 'good design' requires the continuous, concurrent (though not necessarily synchronous) involvement of many different experts throughout the design process. It is also becoming obvious that collaboration means much more than merely moving information from one participant in the design process to the next one: it requires the development of a shared-understanding among the participants. It is our belief that CAAD has a major role to play in facilitating 'true' collaboration, and engendering shared-understanding.

Our approach to facilitating effective collaboration can thus be considered a *combination* of all existing approaches, as discussed earlier: the shared-product approach, the performance-evaluation approach, and the process-oriented approach. By combining them into one, unified whole, and by developing a networked environment where each module is designed to complement and enhance the other modules, we can overcome many of the individual limitations of the separate approaches.

Specifically, our approach adds *valuation* and *deliberation* to the shared product approach, it adds the capacity of the human experts to *identify*, *extract*, *process* and *share* information to the performance modeling approach, and it adds *product description*, *evaluation*, and *contextuality* to the deliberative process. The networking of all three modules into a unified network can help the experts arrive at a shared, high-level view of the emerging product, thereby overcoming their limited disciplinary worldviews. While our solution is technical in nature, we argue that its affect will be qualitative: it will facilitate *effective*, rather than merely *efficient*, collaboration.

Perhaps the most significant overall contribution presented by our approach is *continuity*: it does not revamp existing CAAD research, nor does it depend on scheduled breakthroughs. Rather, it draws on the respective strengths of individual research efforts of the past 50 years, and joins them into a unified new whole. This new whole clearly establishes the roles of the parts, while relieving each part from having to provide a holistic answer, on its own, to the original problem of helping designers to assess the quality, desirability, and the implications of their creations. It is the very maturity of CAAD research at the end of the 20th century that has made such joining of the parts possible, and, we argue, presents a viable and desirable direction for its future.

References

- Amor R., G. Augenbroe, J. Hosking, W. Rombouts, J. Grundy (1995). "Directions in modeling environments." *Automation in Construction* 4(3):173-187.
- Armour G.C. and E.S. Buffa (1968). "A heuristic algorithm and simulation approach to relative location of facilities." *Management Science* 9(2), 294-309.
- Augenbroe G. (1995). "An overview of the COMBINE project." *Product and Process Modeling in Building Industry* (R.J. Scherer, ed.). A.A. Balkema, Rotterdam.
- Axelrod R. (1984). *The evolution of cooperation*. Basic Books, New York.
- Axelrod R. (1997). *The complexity of cooperation*. Princeton University Press, Princeton, NJ.
- Benne B. (1998). *Web-based communication of design information for asynchronous design energy evaluation*. Master of Science Thesis, Department of Architecture, University of California, Berkeley.
- Berger P.L. and T. Luckmann (1967). *The social construction of reality*. Anchor Books, New York.
- Carrara G., Y.E. Kalay and G. Novembri (1994). "Knowledge-based computational support for architectural design." *Automation in Construction* 3(2-3), 123-142.
- Coyne R.D., M.A. Rosenman, A.D. Radford, M. Balachandran, and J.S. Gero (1990). *Knowledge-based design systems*. Addison-Wesley, Reading MA.
- Cross N. (1977). *The automated architect*. Pion Ltd., London, UK.

- Cuff D. (1991). *Architecture: the story of practice*. MIT Press, Cambridge, MA.
- Eastman C.M. (1994). "Computer integration of design and construction knowledge." *Knowledge-Based Computer-Aided Architectural Design* (G. Carrara & Y.E. Kalay, eds.). Elsevier Science Publishers, Amsterdam, The Netherlands.
- Eastman C.M. and A. Siabiris (1995). "A generic building product model incorporating building type information." *Automation in Construction* 3(4): 283-304.
- Flemming U. (1994). "Case-based design in the SEED system." *Automation in Construction* 3(2,3): 123-133.
- Galle P. (1995). "Towards integrated, 'intelligent', and compliant computer modeling of buildings." *Automation in Construction* 4(3):189-211.
- Hacfoort E.J.H. and K.J. Veldhuisen (1992). "A building design and evaluation system." *Evaluating and Predicting Design Performance* (Y.E. Kalay ed.) pp. 195-211. Wiley Interscience, New York.
- Hitchcock, R. (1996). *Improving life-cycle information management through documentation of project objectives and design rationale*. PhD dissertation, Department of Civil Engineering, University of California, Berkeley.
- Hobbs R.W. (1996). "Leadership through collaboration." *AIArchitect* 3:11.
- Jacobsen K., C. Eastman, and T. Sheng Jeng (1997). "Information management in creative engineering design and capabilities of database transactions." *Automation in Construction* 7(1):55-69.
- Jockusch, P.R.A. (1992). "How can we achieve a good design?" *Evaluating and Predicting Design Performance* (Y.E. Kalay, ed.) pp. 37-50. Wiley Interscience, New York.
- Kalay, Y.E., L. Khemlani and Jin Won Choi (1998). "An integrated model to support collaborative multi-disciplinary design of buildings." *Automation in Construction* 7(2,3):177-188.
- Kalay Y.E. and E. Shaviv (1979). "A method for evaluating activities layout in dwelling units." *Building and Environment* 14(4):227-234.
- Khedro T., M. Genesereth and P. Teicholz (1993). "FCDA: a framework for collaborative distributed multidisciplinary design." *AI in Collaborative Design* (Gero & Maher, eds.), pp. 67-82. AAAI, Menlo Park, CA.
- Khemlani L. and Y.E. Kalay (1997). "An integrated computing environment for collaborative, multi-disciplinary building design." *CAAD Futures 1997* (Yunge, ed.). Munich, Germany.
- Khemlani L., A. Timerman, B. Benne, and Y.E. Kalay (1998). "Intelligent representation for computer-aided building design." *Automation in Construction* 8(1):49-71.
- Kim I., T. Liebich and T. Maver (1997). "Managing design data in an integrated CAAD environment: a product model approach." *Automation in Construction* 7(1):35-53.
- Kuhn T. (1962). *Structures of scientific revolutions*. University of Chicago Press, Chicago.
- Llavaneras G. (1996). *Fenestration agent*. Technical Report, Department of Architecture, University of California, Berkeley.
- Mahdavi A., P. Mathew, S. Kumar and N.H. Wong (1997). "Bi-directional computational design support in the SEMPER environment." *Automation in Construction* 6(2): 353-373.
- Mahdavi A. and G. Suter (1998). "On the implications of design process views for the development of computational design support tools." *Automation in Construction* 7(2,3):189-204.
- Manning P. and S. Mattar (1992). "A preliminary to development of expert systems for total design of entire buildings." *Evaluating and Predicting Design Performance* (Y.E. Kalay, ed.), pp. 215-238. Wiley Interscience, New York.
- McCall R., G. Fischer and A. Morch (1990). "Supporting reflection-in-action in the JANUS design environment." *The Electronic Design Studio* (McCullough et al, eds.). MIT Press, Cambridge, MA.
- McCall R. (1986). "Issue-serve systems: a descriptive theory of design." *Design Methods and Theories*, 20(3).
- McCall R., P. Bennett, E. Johnson (1994). "An overview of the PHIDIAS II Hypercard system." *ACADIA '94* (A. Grin, M. Fraser eds.), pp. 63-76.
- Mitchell W.J. (1977). *Computer-aided architectural design*. Van Nostrand Reinhold, New York.
- Mohsini R. (1992). "On measuring project performance: some problems of aggregation." *Evaluation and Prediction in Design* (Y.E. Kalay, ed.) pp.239-250. John Wiley & Sons, New York, NY.
- Cohen R.M. (1944). *A Preface to Logic*. Henry Holt & Co., New York.
- Musso, A. and H. Rittel (1967). *Measuring the Performance of Buildings*. Technical Report. Washington University, St. Louis.
- Papamichael K., J. LaPorta, H. Chauvert (1998). "Building Design Advisor: automated integration of multiple simulation tools." *Automation in Construction* 6(4): 341-352.
- Pohl J. and L. Myers (1994). "A distributed cooperative model for architectural design." *Knowledge-Based Computer-Aided Architectural Design* (G. Carrara & Y.E. Kalay, eds.) pp. 205-242. Elsevier Science Publishers, Amsterdam, The Netherlands.
- Protzen J.P., and H. Dehlinger (1972). "Debate and argumentation in planning: an inquiry into appropriate rules and procedures." *Technical report*, Institute of Urban and Regional Development, University of California, Berkeley.
- Pruitt D.G. (1981). *Negotiation behavior*. Academic Press, New York.
- Raiffa H. (1982). *The art and science of negotiation*. Harvard University Press, Cambridge, MA.
- Rittel H.W. and M.M. Webber (1984). "Planning problems are wicked problems." *Developments in Design Methodology* (Cross, ed.). John Wiley, New York, NY.
- Shaviv E. and G. Shaviv (1977). "A Model for Predicting Thermal Performance of Buildings." *WP ASDM-8*, Faculty of Archi-

ecture and Town Planning, Technion, Haifa, Israel.

Shaviv E., A. Yeziro, I.G. Capeluto, U.G. Peleg and Y.E. Kalay (1996). "Simulation and knowledge-based computer-aided architectural design (CAAD) systems for passive and low energy architecture." *Energy and Buildings* **23**: 257-269.

Shibley R.G. and L. Schneekloth (1988). "Risking collaboration: professional dilemmas in evaluation and design." *Journal of Architecture and Planning Research* **5**(4):304-320.

Simon H.A. (1969). *The sciences of the artificial*. MIT Press, Cambridge, MA.

Steinfeld E. and Y.E. Kalay (1990). "The impact of computer-aided design on representation in architecture." *ARCC Conference on Representation and Simulation in Architectural Research and Design*. Minneapolis, Minnesota.

Sun M. and S.R. Lockley (1997). "Data exchange system for an integrated building design system." *Automation in Construction* **6**(2):147-155.

Sycara K. (1988). "Resolving goal conflicts via negotiations." *Ninth International Joint Conference on Artificial Intelligence*, pp. 245-250, Los Angeles, CA.

Timerman A. (1998). *The ALPHA Project Object Database*. Master of Science Thesis. Department of Architecture, University of California, Berkeley.

Valkenburg R.C. (1998). "Shared-understanding as a condition for team design." *Automation in Construction* **7**(2,3):111-121.

Wiesel A. and R. Becker (1992). "Integration of performance evaluation in computer-aided design." *Evaluating and Predicting Design Performance* (Y.E. Kalay ed.) pp. 171-181. Wiley Interscience, New York.

Yaski Y. (1981). *A Consistent Database for an Integrated CAAD System*. PhD Dissertation, Carnegie Mellon University.