

STANDARDIZATION IN PRODUCT AND PROCESS DATA MODELLING : THE ISO STEP AND MANDATE STANDARDS' CONTRIBUTION TO THE INTEGRATION OF THE LIFE-CYCLE OF BUILDINGS

AF CUTTING-DECELLE (*)

ABSTRACT :

In this paper, the data exchanges during the construction process will be analysed through the presentation of the specificity of the profession, and the description of the construction process, by means of the different related models. We will then present the two standards, STEP and MANDATE, both currently under development, first in their main features, then by the concepts they will be able to provide. We will focus on a presentation of MANDATE, since one of the models provided could be useful for the representation of the life cycle of buildings. This paper will end with some perspectives for the building construction domain, based on the integration of the whole construction process.

INTRODUCTION

Design and construction of buildings is essentially an information processing activity, particularly in the early phases of design and planning, where no physical structure exists, but only related information. Also, with the intensive use of computers, it more and more becomes a problem closely related to the developments made in the domain of Information Technologies. On the other hand, the construction process involves, whatever the stage, a lot of people coming from different organisations, with various roles. Those persons have in common to work on the same building, each of them with his own knowledge, his own language to express this knowledge, his own way of working, and very often, consequences of misunderstanding may be of a great importance to the cost and the quality of the construction.

Exploration of new ways of working has been driven on the basis of such considerations, and all of them lead to the integration of design and construction, into a global "Design for Construction", or "Design for Manufacturing" approach. In this paper, we will try to analyze how the activities in standardization, at the international level, in the domain of product, and process data may help to reach this new "overall organization" of the work.

We will first examine the data exchanges in the building construction sector, according to the specific features of the profession, the type of information to be processed, the corresponding problems, and the need of standardized ways for

(*) Université de Savoie, ESIGEC/LGCH, Savoie Technolac, F 73376 LE BOURGET DU LAC
CEDEX, Tel : 33 79 75 88 16, Fax : 33 79 75 87 72, Email : afcd@univ-savoie.fr



exchanging data. We will present the work undertaken at the international level in the domain of product, and process data. Then we will analyze the capabilities of those future standards to integrate the whole building construction process.

1. DATA EXCHANGES DURING THE BUILDING CONSTRUCTION PROCESS

1.1 Specificity of the sector

The construction sector is characterized, in comparison with other discrete manufacturing industries, by an immense diversity of products and processes, and also by a far-reaching separation of design, construction and maintenance. Conventional market practices, and the construction industry's overall fragmentation (the companies range from very large and worldwide companies to very small ones) constitute major constraints that inhibit integrated product development. Transient, or even adversary relations, rather than "co-makership" prevail among the participants of the building process. Furthermore, the product to be made is **unique**, the construction of a new project will need the elaboration of complete new relations between the new, and different, partners of the building project. The team is usually built around a given project and it gathers an heterogeneous set of partners. Compared with other industrial sectors, overall productivity [Laitinen] in the building construction sector has not increased. One of the main reasons for this is due to the fact that the quality of the whole construction process has remained at a low value : for example, according to several European studies, the error cost counts for 5 to 10 % of the total building cost, the errors with greatest economic impact occurring in design, project management and construction on site. This is largely due to the low level of industrialisation of the building process.

Since the different interveners of the building construction are highly inter-related, a simultaneous, or "concurrent" way of working would help to provide an organisational framework for the mutual adaptation [Pols] between the design and construction processes. Such capabilities would allow to take account of the requirements of the construction and maintenance stages from the design stage.

Integrated product development is of vital importance to improve the quality of the "building", it is also the only way to lower costs and reduce development time.

The building construction domain also represents an immense amount of information to be managed, when necessary, without forgetting the storage.

During the construction process [Rio], the project partners exploit existing information, usually coming from other partners, but they can also create new information. Each partner only needs a part of the whole project information, he also needs to adapt it in order to make it understandable by his own tools and he is allowed to enter/modify only a part of it. However data must be available when needed and the consistency of the whole must be maintained.

With the development of integration, some requirements are to be taken into account : [Cutting1]

- **Necessity for all the required information to be stored in an adequate way, enabling its use by all the partners involved in the different stages of the construction process, without duplication or loss in spite of the multiplicity of the**

access points, or the view points of the different partners. To satisfy this requirement, each stage of the construction process, and all the information flows between them must be identified. Also, since the use of predefined elements (such as the components classified in "libraries") is increasing, the system must provide the most proper way of extracting the relevant information. Furthermore, due to the building life cycle, a long term storage (50 to 100 years) has to be ensured.

- **Need for technical solution archival and retrieval functions**, because the previous projects constitute the knowledge base of the company.

1.2 The construction process, and the related data

A lot of work is currently underway in this domain, and it would be nearly impossible to mention the different process models available, or in progress. We can however notice that the "building" is more and more defined through its life cycle, and not as a set of isolated data, corresponding to the mere description of its components.

1.2.1 The construction process

Applied to building as, besides, to other construction facilities, the construction process is concerned with the building's complete lifespan, from the client's first thoughts through to demolition, including design, production, operation and maintenance. Numerous models do exist to represent the whole construction process : among them, and without any research of exhaustivity, we can mention IRMA (Information Reference Model for AEC) [Froese], generic model of high level concepts involved in projects, with a particular focus on the processes involved and their relations to facilities, products, resources, people. Another model is provided by the BP/RIM project [BP/RIM], whose purpose is to establish a Building Process Reference Information Model, a common conceptual and terminological framework of understanding of the building process, its "agents" and "information flows" among the participants of the European EDI-standardization EDIFACT Board MD5.

Whatever the way of proceeding, the complete building life cycle may roughly be subdivided into three stages, which are : **Creation, Use, Decomissionning** [ISO TC59] (fig. 1). Those phases can be, in turn, partitionned into the following activities, and sub-activities, according a taxonomic procedure :

- **Inception** : surveying the site, assessing user requirements,
- **Design** : collecting data, synthesising, drawings, cost estimating,
- **Production** : planning, ordering materials, fixing, finishing,
- **Use** : regulating, cleaning, repairing, maintaining,
- **Decomissionning** : salvaging materials, protecting the public, demolishing.

The Fig. 1 shows that the construction process is long : there are normally at least 50 years between the birth of a project idea, and the remodelling or decomissionning of a typical building. The same characteristics holds for the construction of a new facility, or for the alteration, or renovation of an existing one.

CREATION			USE	DECOMMISSIONING
INCEPTION	DESIGN	PRODUCTION		
Example activities :	Example activities :	Example activities :	Example activities :	Example activities :
Assess suitability of site	Environmental and space design	Production planning	Facilities management	Demolition
Assess financial viability	Constructional design	Product Supply	Facilities operation	Environmental + safety management
formulate design brief		Construction/ installation	Facilities maintenance	
		Time/cost/ quality management		
Normally less than 1 year	Approxim. 1-5 years	Approxim. 1-5 years	Up to 100 years	Normally less than 1 year

Figure 1 : the phases of the construction process

The conventional building design computer representations are described in drawings, and related contract specifications, but they do not include all the information needs of the construction process, e.g. the global product information needed for tendering, and planning. For example, the available technologies and resources, with associated costs and times are essential for the assessment of the constructibility during the entire design process.

An integrated approach to building product and process modelling is necessary to effectively support "concurrent", instead of merely sequential development of design and construction. With this approach, it will be possible to take into account the common feedbacks between the different phases of the overall process, and thus to solve, as soon as they appear, the problems they bring out.

1.2.2 Dynamic view of the construction process

The description of the construction process with sub-processes, and tasks, each of them consuming large amounts of economic and physical resources, and being transformed into results, leads to the definition of information flows between the tasks and identification of the actors information requests.

It will be then necessary to represent, to model those information flows, thus giving rise to *Product Models*, and also to identify the requests, to characterize them, by means of *Process Models*.

A rough view of the construction process may be given by the following schema, which may also be considered as a generic view of the whole process (Fig. 2).

This diagram underlines both the complexity of the information flows and the strong link of the information flows with the social and economical organization of the construction process.

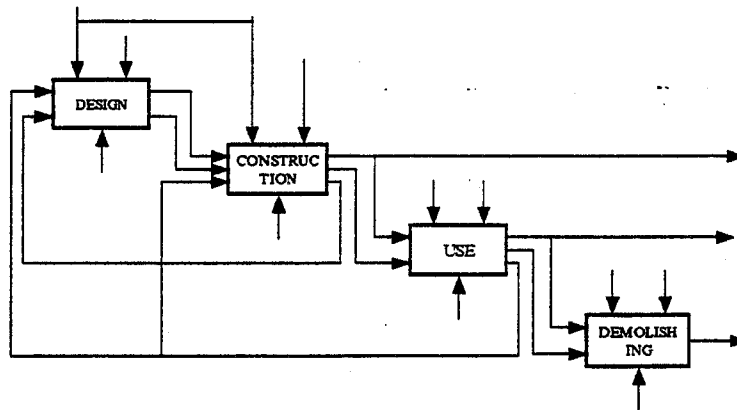

Figure 2 : process model of the construction cycle : generic view (from [BP/RIM])

1.2.3 Corresponding models

Information modelling applied to the engineering world separates three kinds of concepts [IMPACT] : products, activities (used for all the production processes), and resources (for the production process), represented in three main models :

* The **product data model** : generally defined as "a conceptual description of a product, capable of structuring all the information necessary for the design, manufacturing and use of that product". A building product data model should be able to serve as an information framework during the entire life cycle of a structure and for all the partners involved. No single person holds the entire model in all its details : it is in fact a distributed model, partially owned and held by each participant to the building act, corresponding to the information flows of the former diagram. The product data model will have to provide the capability to represent all the product characteristics ranging from single parts, assemblies of components, to the building considered as a whole, whatever the access point : structure, HVAC, project management, services.

* The **process model** : consists of information (process data) describing the production activities (design, planning, construction), structured by processes, operations, and paths. It may also shed light upon the fact that some products are incorporated into other products (e.g., concrete is consumed during the process of making a concrete wall). Traditionnally [Hannus], schedules of the various phases of building projects have dominated the way in which professionals model construction processes. In parallel, organisational schemes are used to show the contractual relationships between partners. Unfortunately, these "models" are highly project-dependent, and do not remain valid if essential changes are introduced into the process. The lack of more abstract models has thus frozen the industry's procedures to traditional ones.

* The **factory model** : structures the information for manufacturing facilities, machine tools, robots. This model depends on the company, and will not be taken into account in this paper.

1.2.4. Relations between product, and process models

These models are not independent, but they share a number of data, representing the "dynamicity" of the construction process, and defining the knowledge of at least a part, of the product life cycle [Cutting2]. The intersection between those

models has to be highly interactive, particularly within a context of Concurrent Engineering. The behaviour of this intersection will have to be modelled in a dynamic way, both in terms of space, e.g. for taking into account the specificity of the site where the building is to be erected, and in terms of time, to correctly manage the sequence of the tasks to be done.

In a simple way, a product may be seen as the outcome of one process, it will then be incorporated into subsequent processes [Toms], according to the schema (Fig.3).

It is also important to clearly separate the product itself (the building), from the way of getting it : this remark being, as we will see further in this paper, at the origin of the MANDATE work.

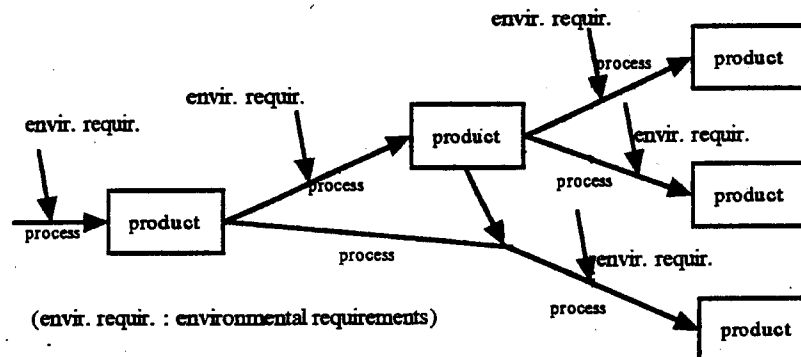

Figure 3 : Generic view of the transition between product, and process [Toms]

1.3 Problems arising, and possible answers

The information processing in the construction sector gives rise to a lot of problems, mainly related to communication, either between computers, or between the different actors involved. All these points lead to a diminution of the quality of the product to be delivered at the end of the whole construction process, along with an important increase in the cost of the construction to keep the quality at a high level.

Although the information is processed by computers, the essential part of the communication in the construction process still relies on human interfaces, and the quality of the building can also be associated with the quality of human exchanges during the overall process.

To improve the mutual understanding of all the actors involved, in between them, and during the whole construction process, we need a "standardized interfacing", a "common language" enabling communication between them, at whatever stage of the process, and whatever the nature of the message. This will be realized by standardization of the exchanges at three levels :

- **message** : characterization of the format of the message to be exchanged between the partners,
- **product data** : by means of a product model,
- **process data** : to characterize the same process in the same way, with the same knowledge : by means of a process model.

2. THE ISO TC184 / SC4 WORK : STEP, AND MANDATE

The scope of the ISO TC 184 Committee (Industrial Automation Systems and Integration) [ISO TC184], in charge of the development of those two standards, is : "standardization in the field of industrial automation and integration concerning discrete part manufacturing and encompassing the application of multiple technologies, i.e. information systems machines and equipment, and telecommunications".

The committee is composed of five sub-committees, among which the SC4, "Industrial Data", whose area of work is given by the "standardization in the field of data and languages of manufacturing applications". The standardization efforts for Product Data Representation appear through the three areas of scope, which are : representation of Product Definition Data, Structure of Part Libraries, and Industrial Manufacturing Management Data. Those areas will lead to the three standards : ISO 10303 STEP, ISO 13584 P-LIB, and MANDATE.

2.1 STEP (STandard for Exchange of Product model data)

ISO 10303 is an International Standard for the computer-interpretable representation and exchange [Part 1] of **product definition data**. This concept of "**product**" ("*thing or substance produced by a natural or artificial process*"), is a powerful and original feature of the standard, compared to other exchange standards [Bezos]. The objective is to provide a mechanism capable of describing **product data** ("representation of facts, concepts or instructions about one or more products in a formal manner suitable for communication, interpretation, or processing by human beings or by automatic means") throughout the life cycle of a product, independent from any particular system. The nature of this description makes it suitable not only for neutral file exchange, but also as a basis for implementing and sharing product databases and archiving. The standard is organized as a series of parts, each published separately : description methods, integrated resources, application protocols, abstract test suites, implementation methods, conformance testing.

Fundamental principles : STEP separates the representation of product information from the implementation methods used for data exchange. The representation provides a single definition of product information common to many applications. This common representation can be tailored to meet the needs of specific applications. Application protocols specify the representation of product information for one or more applications. The standard specifies the implementation methods that support the representation of product information included in application protocols, and provides a methodology and a framework for the conformance testing of implementations. It can be used whatever the industrial domain, and whatever the manufactured products : automotive industry, ship building, construction, CAD/CAM, aerospace industry.

It must be noticed that, in the domain of process plan, the Part 49 (Working Draft) deals with "Process structure and properties", in terms of static specifications, and requirements that must be satisfied by the process.

2.2 MANDATE (MANufacturing DATa Exchange)

MANDATE tries to define a common representation of all the manufacturing information. Manufacturing management is the answer to the question : "HOW do we manufacture products ?". The ISO definition of "manufacturing" is given, as "the function of directing or regulating the orderly movement of goods through the entire production cycle from requisitioning of raw material to the delivery of the finished product".

Within an industrial company [MANDATE, N1], activities are triggered, controlled and evaluated by a lot of information reflecting decisions, measures, facts or events. It is not possible to pre-determine all of them because of their specificity. But a logical modelling has to be done, to enable a physical extraction of the corresponding information, and its exploitation.

Two main technical information flows exist within an industrial company : one related to the products, another one related to the activities to sell, produce, purchase, assemble the products. MANDATE deals with the second one. STEP will consider the product as a well-known object, while MANDATE is interested in the stages of transformation within the company.

Method of work : since MANDATE is included within the SC4, most of the tools used for the developments will have to be common to the other activities undertaken within the sub-committee. In order to save time, work has been split between into three parallel projects, with three scopes, which are :

* **Project 1 :** to develop an international standard dealing with model, form, and attributes of data exchanged between an industrial manufacturing company and its environment of manufacturing management activities.

* **Project 2 :** to develop an international standard dealing with model, form and attributes of data able to reside in an industrial manufacturing company's resource database.

* **Project 3 :** to develop an international standard dealing with the model, form, and attributes of the data controlling and monitoring the flow of materials within the industrial manufacturing company.

Those three projects may be represented, schematically, according to the Fig. 4 :

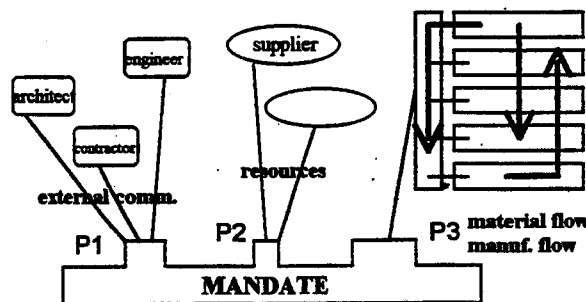

Figure 4 : Schematic representation of the MANDATE's functions

In the following section, we will try to analyze the capabilities of STEP and MANDATE, to integrate the life cycle of buildings, and its specificities.

3. CAPABILITIES OF STEP AND MANDATE TO INTEGRATE THE LIFE CYCLE OF BUILDINGS

3.1 Concepts provided by STEP [Arbouy]

Those concepts are worked out within the framework of AEC (Architecture, Engineering and Construction) activities, by the WG3 Working Group (Product Modelling), its global working area ranging from ships, petrochemical plants, offshore structures, to buildings. To date, since developments have rather been focused on either generic resources, or application protocols, STEP supplies entities more generic (Generic Resources) than directly applicable to a specific domain (Application Resources).

Works are currently on going to provide STEP with an actual knowledge of the building construction domain, with the developments made within the framework of the Building and Construction Application Protocol Planning Project [BC-APPP] : the aim is to create a basic sub-structuring of the building domain to facilitate initiation of "bottom-up" activities in the development of industry application protocols, and supporting resource models, nevertheless recognising the need for effective integration strategies for handling interaction amongst the various building systems (e.g. space, structure, HVAC, ...) and between AEC sectors based on a "top-down" approach. The APPP Framework will provide a Core Model, AEC resources, and other more specialized resources, dedicated to a specific family of application protocols. Current developments are made in the domains of the Core Model, of steelwork structures (AP), HVAC (AP), and spatial arrangements (AP). Other on-going developments will lead to the AP 225, "Structural building elements using explicit shape representation", in the domain of the geometrical representation of parts.

3.2 Concepts provided by MANDATE

Since the beginning, MANDATE work has been intended to be applicable to industrial manufacturing activities. It would be interesting to see whether the concepts provided by the future standard are applicable to the building construction domain, or not.

MANDATE activities being split into three projects, the concepts provided will depend on the project they refer to. We will analyze them in a separate way.

- **Project P1** : refers to the external communication. The aim is to model the main information exchanged between industrial companies, using the EDI protocols. The domain of the project [WG8/P1] includes all information—and functions necessary to support quality and order management, such as planning, executing, controlling and monitoring of product quality, orders and shipments. This includes all data describing order flow. For planning, executing and controlling, the necessary input and output data will have to be considered, as well as the data which have to be exchanged with customers, material and service suppliers. This project, very active, also provides a link of quantity, and time with resources (Project P2), during order execution. Providing an information base for planning,

executing and controlling of orders, the project P1 thus provides the input information as a framework to enable material flow control (Project P3).

The standard will have to enable a formal description of order information exchange with customer and the supply chain, allowing order management (planning, execution, controlling and monitoring of orders). The same formal description will be expected from quality information exchange, under the same conditions for the quality management. It will of course have to capture the semantics of the previous functions. Specific classes, attributes and class libraries will have to be developed to satisfy the requirements or the previous goals.

- **Project P2** : refers to the resource usage management, [WG8/P2] such as resource configuration and capabilities, operation management of manufacturing devices, installation and facilities ; it also includes quality-features, and safety-features. Raw material, or intermediate products, clearly product-related, are out of the scope of MANDATE, and within the scope of STEP.

Three different aspects must be considered about the resources :

- their description, the way of using and maintaining them, outside MANDATE,
- the description of the functionalities a resource is able to give, its capacity and capability, which are within the scope of MANDATE,
- the information model to trigger, estimate and monitor the resource, which is within the scope of MANDATE.

The description of capacities, and capabilities of the resources (the functionalities) must be modelled at a very generic level, allowing some "companion standards" to use this generic model to make up a more precise one, about resources for a specific industrial activity, or a specific function.

- **Project P3** : refers to the flow material control, and intends to standardize [WG8/P3] data elements, and functional elements, which support the control and monitoring of the flow of material in industrial manufacturing processes. This includes all the elements describing the material flow, including inventory and resource management.

The goals of the project are, on the basis of existing standards for process plans, to develop a standard enabling the description of :

- materials' flows in industrial discrete manufacturing processes,
- all the information necessary for scheduling, controlling and monitoring the flow of material.

Appropriate related standards will be considered in this work, among which STEP, EDIFACT, MMS, PrENV 40003 [PrENV 40003], (Entreprise Modelling), and the formalisms developed will have to support these interactions.

In this paper, we will mainly focus on this project, since corresponding work is probably the most advanced in terms of documents issued.

One of the first stages consists of the definition of a model of the production process (material flow, and information flow). The building blocks provided by this model must allow each company to individually model the relevant monitoring and control information - with a maximum of flexibility relative to changing situations and the possibility of adapting to changing organizational circumstances. The constructs contain the semantics, and support for the interactions between the different monitoring and control systems. They also support the modelling of interfaces with related organizational functions, such as product design, process

planning and quality assurance. The building blocks are semantic information units that can be specialized and instantiated to describe any information relevant for planning, scheduling, monitoring and control certain manufacturing processes in different levels of abstraction. All the concepts manipulated by those constructs will, of course, be highly time-related. However, it is not the aim of this project to develop a reference model valid for all the manufacturing processes. This first step will then be followed by an analysis of problem specific algorithms and methods, in the domain of scheduling, with partly contradictory targets, to be resolved in one single decision. For this step, tools and methods of Operational Research, and Artificial Intelligence have to be examined. Those algorithms will have to accommodate the special requests of controlling, and monitoring systems, notably interruptability, and must allow for the inclusion of the available knowledge. Then, the next step will be the development of required services, in order to address the problem of the interruption of scheduling, planning and monitoring processes, notably the occurrence of unsolicited trouble-messages, and to manage, in an interactive way, the simulation of different situations.

It is interesting to see how the concepts provided by this project could be used in the construction domain - however, we must not forget that the work presented here, made within the framework of MANDATE is very complex, theoretical, since the concepts are intended to be general, applicable whatever the kind of discrete processes, and the industrial companies.

NB : Distinction between STEP, Part 49 "Process structure and properties" and MANDATE : STEP Part 49 [Part 49] deals with the elements of a process plan, defined as the specification of instructions for a task. Without specifying any particular process, this part defines the elements for exchanging process information, and specifies the information necessary to represent the execution of a process including the relationships between the steps within the process. The process plan can be used to refer to, or enhance a product definition, or simply be a set of instructions to complete a task without regard to a product definition. If the whole static environment of a "process" is dealt with by this Part, nonetheless process planning, in its dynamic features (scheduling, dynamic monitoring and control), does not belong at all to the scope of STEP, but to MANDATE's.

In the following sections, we will mainly focus on the works made within the framework of the Project P3, since they better correspond to the needs of the construction sector in terms of building life cycle, from a point of view of process management.

3.3 MANDATE's information model for manufacturing/material flow processes (project P3)

The design method used for defining this model [Dangelmaier1], [Dangelmaier2] has to create general interfaces for shop floor planning, scheduling and control between all subsystems and CAD, NC machines-tools, warehousing, dispatch. The contracting firm, or the workshop, is considered as a black box, with input/output objects. The transformation function of the black box is, at the beginning, unknown, or undefined. For planning and control, the factory has to be structured into parts, each of them having an perfectly defined behaviour. **Objects**, in the

project, but also all the key-points in time where main decisions are taken, and choices made.

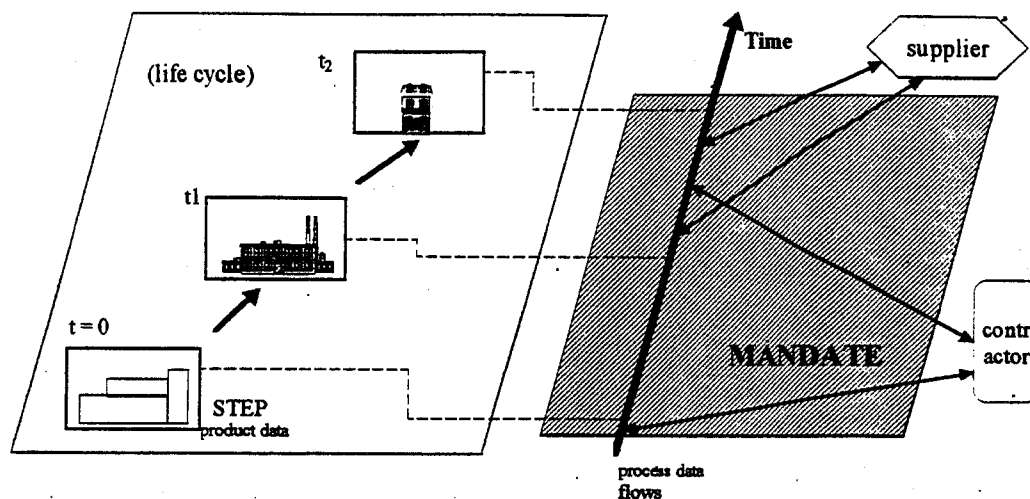

Figure 8 : possible couplings between STEP and MANDATE

MANDATE, with its three axes, would enable a dynamic and adaptative management of the partners involved in the construction process, according to the dates, the conditions of their interventions, it would also facilitate the transfer of knowledge from the early stage of design, towards the construction phases. It would also probably make easier the global planning of the construction, and the way of managing the modifications, and the feed-backs.

Associated with other related standards, such as EDIFACT, and the future ISO 15926 P-LIB [Pierra] (components used in the project), it would be possible to provide a unified way of dealing with all the information related to the whole building, whatever the stage of evolution of the project, and within an IT context, thus enabling the improvement of the whole construction process - and the quality of the end-product, the building.

CONCLUSION, PERSPECTIVES

Mutual integration of design and construction, resulting in concepts such as Design for Construction [Luiten] (DfC), or Design for Manufacturing (DfM), or even Concurrent Engineering (CE) are important issues for the Building Construction Industry in the future. If a lot of problems still remain unresolved, the use, more and more significantly, of new Information Technologies concepts will help to make attainable the final goal of the improvement of the productivity of the sector, and the quality of the products to be made.

In this context, the development of international standards aimed at the exchange of project information, of whatever type, proves to be an indispensable stage, however the worldwide acceptance of those standards is not of the least importance, since some of them may lead, in the future, to changes in the current way of working of the different actors involved in the whole construction process.

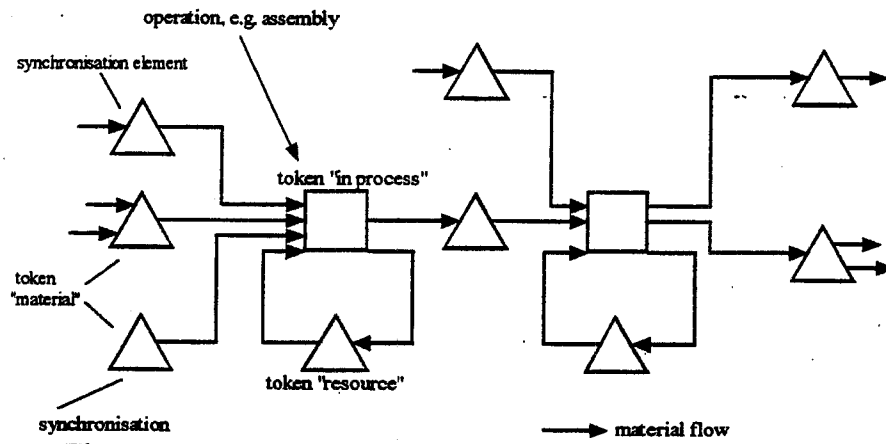

Figure 6 : example of a manufacturing/material flow process

Time considerations are taken into account within the time model, by means of flows of tokens allocated to points of time, those points of time being obtained by counting up either flows per period, or cumulated flows, or even flows per period, given by direct addressing, according to the general representation of the Fig. 7 :

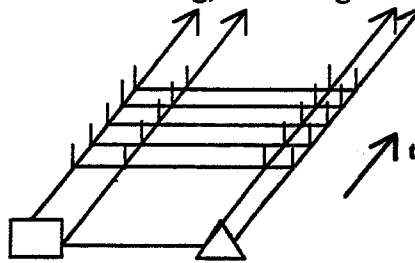

Figure 7 : third axis :
role of the time

The global model of the manufacturing process will be the 3D representation, obtained by superposition of the plane (see Fig. 6), and the time axis (Fig. 7). The "grammar" of the model then leads to behavioral rules between the different objects, and hierarchies that may be "operation-oriented", or "objects (attributes, or location)-oriented". This modelling is adaptative, since flows of information may affect the operations, or the objects, according to rules, or sets of rules.

3.4 Application to the construction domain

Applied to the building construction domain, the previous concepts seem to correspond to an approach of the construction process information management oriented, respectively product data, for STEP, and process data, for MANDATE. If STEP is able to provide a "snapshot" of a product, at a given time, and in a given state, MANDATE, through its dynamic study of the processes, brings in the time dimension, thus enabling life cycle considerations, and provides a backbone for couplings between the engineering product information and the corresponding engineering processes [Syvertsen], as we can see on the Fig. 8.

Life cycle definition has to encompass not only the different phases of a building life, as stages of its development, but also the versions, and variants of the initial

factory can be described by : a set of **attributes**, their location (**space**), a **time**, all of them together defining the **State** of the object. The state of the whole factory will be the sum of the states of all the objects. State, and time are special attributes, with a dimension, enabling a measure of the distance between two points. An object is defined in space and time by a set of attributes, according to the manufacturing, dimensionless, those attributes will have to be fulfilled by the manufacturing process. For planning and control, only some attributes, locations and points of time are relevant. Defining the relevant objects for a given concept, e.g. "Necessity for planning and control" will result in discrete values for the different corresponding models. Between objects needing decisions to be taken, the manufacturing process is modelled as a black box with "continuous flow", defining an **operation**. The model of the manufacturing process is provided by the three models of the sets of attributes, time, space, all together defining the possible states of the factory. To make a schedule, or a plan, production planning and control will have to define the relevant states (attributes, space, time) in the model. Normally, a set of attributes defines a **class of objects**, not a single object : e.g., a class of drilling machines ; a **set of objects** in an object class is modelled by **tokens**. A token represents an object, in a attribute, time and space model. The flow of tokens in the three models describes all the changes in the factory, also called **events**. A **plan** corresponds to a complete evaluation of objects and operation, by means of tokens, it is also a completely evaluated model of the manufacturing process.

Graphical representation : on a 2D-plane (attribute/space, and time), with different symbols (Fig. 5), and a time axis vertical in comparison with attributes/space dimension. The model of objects/attributes, and operations is called process plan/workplan.

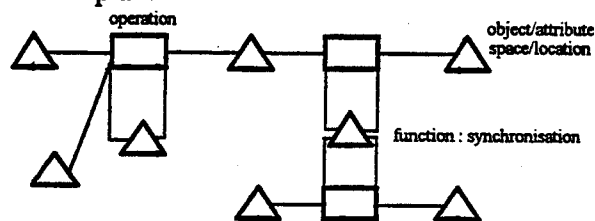

Figure 5 : graphical representation of a workplan

The Δ symbol is not only the symbol of an object/attribute, it can also have a function of **synchronisation** :

- without modification of attributes, only consumption of time,
- Δ represents a certain state/object/attributes location,
- synchronisation of operations (transformation from one object/state to another).

An operation generally modifies the tokens (tools, machines, ...). At the end, all the tokens leave the system. Each token may own an individual **time model** (time unit, capacity). A material token runs through an operation only once, a resource token may run through an operation several times, if necessary. A general schema is represented on the Fig. 6 :

Those changes will undoubtedly have to occur as progressively as possible, they are however of a vital importance for a lot of companies within this industry, for their survival confronted to the international competition.

Through STEP, and MANDATE, ISO is addressing two key-issues of the Computer Integrated Construction. The work, up-to-now, is mainly theoretical, and needs to be completed, tested on real-life cases, and better known, disseminated to industrial companies - this will be the only means to make sure that they become *de facto* standards, really used by the industry.

Bibliography :

- [Arbouy] : S Arbouy, A Bezos, AF Cutting-Decelle, P Diakonoff, P Germain-Lacour, JP Letouzey, C Viel, STEP, Concepts Fondamentaux, AFNOR, 1994
- [BC-APPP] : Application Protocol Planning Project for Building-Construction, ISO TC184/SC 4/WG 3, N 315
- [Bezos] : A Bezos, STEP, the ISO 10303 standard for product data exchange and representation. CODATA Congress, Chambéry, 1994
- [BP/RIM] : P Hauch, EDIBUILD BP / RIM, BPS-centret
- [Cutting1] : AF Cutting-Decelle, AM Dubois, Data Exchanges in the Building Industry, CODATA Congress, Chambéry, 1994
- [Cutting2] : AF Cutting-Decelle, AM Dubois, Product Data handled by STEP : considerations, and proposals. Proceeding of European Product Data Technology Days, in Revue internationale de CFAO et d'infographie, March 1994
- [Dangelmaier1] : W Dangelmaier, Project 3, Information model for manufacturing/material flow processes, design method, ISO TC 184 / SC 4 / WG 8 N8
- [Dangelmaier2] : W Dangelmaier, K Geck-Mügge, N Ketterer, Information Model for Manufacturing Process monitoring and control, ISO TC184 / SC4 / WG8 - P3, Version 0.3, March 1995
- [Froese] : T Froese, Summary of Stockholm Workshop, April 1994, email
- [Hannus] : M Hannus, Information models for performance driven computer integrated construction, CIB W78 Workshop on Computer Integrated Construction, Montreal, 1992.
- [IMPACT] : WF Gielingh, AK Suhm, IMPACT Reference Model, Project 2165, Research Reports ESPRIT, Volume 1, Springer-Verlag, 1991
- [ISO TC184] : ISO TC 184 N 337, report of the Secretariat prepared for the 8th meeting in Turin, May 1995
- [ISO TC59] : ISO TC59 / SC13 / WG2, Classification of Information in the Construction Industry, ISO Technical Report (Type 2), December 1993
- [Laitinen] : J Laitinen, Cocoon Project, 1993
- [Luiten] : B Luiten, F Tolman, Computer Aided DfC (Design for construction) in the Building and Construction Industries, 1992
- [MANDATE, N1] : MANDATE, Rationale, ISO TC184 / SC4 / WG8 N1, 1991
- [Part 1] : ISO 10303-1, Overview and fundamental principles, IS, 1995
- [Part 49] : ISO 10303-49, Process structure and properties. WD, ISO TC184/SC4/WG3-N360, November 1994
- [Pierra] : G Pierra, Modelling Classes of Pre-existing Components in a CIM Perspective : the ISO 13584/ ENV 40004 Approach. Proceeding of European Product Data Technology Days, in Revue internationale de CFAO et d'infographie, pp 435-453, March 1994
- [Pols] : A A J Pols, Towards Integrated Support for Computer Integrated Building, pp 41-50, Elsevier 1992
- [PrENV 40003] : CEN TC310 / WG1, Computer Integrated Manufacturing - Systems Architecture - Framework for Enterprise Modelling, DS/INF 61, København, 1990
- [Rio] : O Rio, A Recuero, M Alvarez, A Suárez, Towards the Integration of the Design Process, 1st Workshop of the European Group for Structural Engineering Application, Lausanne, March 1994
- Syvertsen] : T G Syvertsen, Object Oriented Product Modelling, ARECDAO, Barcelone, 1991
- [Toms] : P Toms, Categorisation of design information in terms of design process and product specifications for a standard for computer representation of specifications, 1992
- [Van Nederveen] : S Van Nederveen, View Integration in Building Design, Management of Information Technology for Construction, pp 209-222, Singapore, 1993
- [WG8/P1] : MANDATE, Electronic Data Interchange, Draft, ISO TC184 / SC4 / WG8 P1 - N16, 1992
- [WG8/P2] : MANDATE, Scope of the Project 2, Resource Usage Management, ISO TC184 / SC4 / WG8 P2 - N 13, WZL, TH Aachen, July 1992
- [WG8/P3] : MANDATE, Project 3, Flow control, Strategy, ISO TC184 / SC4 / WG8 P3 - N 14, Heinz Nixdorf Institut, July 1992