

EMPIRICAL ANALYSIS OF KNOWLEDGE MANAGEMENT ACTIVITIES IN CONSTRUCTION ORGANISATIONS

Le Chen¹ and Sherif Mohamed²

ABSTRACT

Knowledge is a commodity. It is a by-product of learning that involves the creation, sharing, processing and possible use of information in the mind of an individual. Knowledge management (KM) is, therefore, concerned with the effective implementation of such activities within the organisation. It is simply the process of leveraging organisational knowledge to deliver a long-term competitive advantage.

This paper presents the results of an empirical research investigation into the interaction between different KM activities within the context of construction contracting organisations. The different KM activities include: responsiveness to the knowledge of business environment, knowledge acquisition, knowledge dissemination, and knowledge application. A questionnaire survey was administered to investigate the opinions of construction professionals regarding the intensity of activities currently implemented by their organisations to facilitate knowledge capturing, sharing and application. A total of 149 responses were then used to statistically examine the inter-relationships between the different KM activities as practised by contracting organisations in Hong Kong. The paper presents and discusses the survey findings and proposes recommendations for improving the effectiveness of current KM practices.

KEY WORDS

knowledge management, contractors, knowledge acquisition, knowledge application.

INTRODUCTION

Knowledge Management (KM) is defined as a process that focuses on knowledge-related activities to facilitate knowledge creation, capture, transformation and use, with the ultimate aim of leveraging organisations' intellectual capital to achieve organisational objectives (Cavaleri 2004). Hence KM activities have been classified and studied according to the ways in which knowledge is dealt with in the operations of organisations with a view to increasing the efficiency and effectiveness of these activities in achieving organisational goals (Shankar et al 2003). It is suggested that KM activities can be strategically classified into four (4) key dimensions: i.e. responsiveness to knowledge within the business environment; knowledge

¹ PhD candidate, School of Engineering, Griffith University, PMB 50 Gold Coast Mail Centre, Queensland 9726, Australia, Phone +61 (0)7 5552 9068, FAX +61 (0)7 5552 8065, l.chen@griffith.edu.au

² Professor, School of Engineering, Griffith University, PMB 50 Gold Coast Mail Centre, Queensland 9726, Australia, Phone +61 (0)7 5552 8575, FAX +61 (0)7 5552 8065, s.mohamed@griffith.edu.au

acquisition; knowledge dissemination; and knowledge application (Abou-Zeid 2002). As these activities are carried out through human interactions they are not interdependent of each other (Diakoulakis et al 2004). Nonaka and Takeuchi's (1995) knowledge creation model reveals the existence of the inter-relationships between knowledge-related activities. As efforts to establish the strategic effectiveness of KM activities continued, conceptual models were proposed to depict the interactions among KM activities (Diakoulakis et al 2004; Kalling 2003). Nevertheless, despite recent efforts in conceptual model proposition and exploratory studies, the number of empirical studies into KM in the construction industry has been limited (Egbu et al 2003a), and the relationship between KM activities has not been empirically tested.

This paper reports a study aiming to provide answers to two (2) major research questions: Do the different categories of KM activities affect each other? And if so, how do they interact? A conceptual model is proposed to empirically investigate these issues within the single business firm environment of construction contracting organisations. The model hypothesises that KM activities, i.e. *responsiveness to knowledge*, *knowledge acquisition*, *knowledge dissemination* and *knowledge application* interact with each other. Figure 1 presents the definitions of the four (4) constructs in the model, and also illustrates the hypothetical relationships between them.

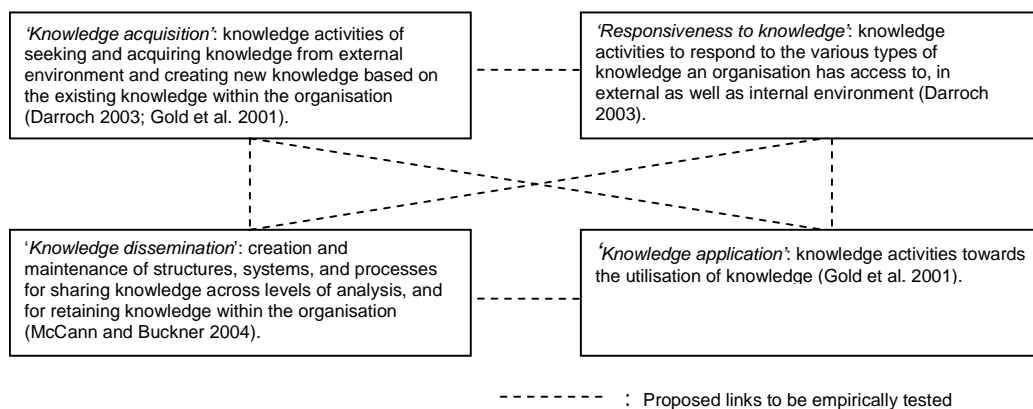

Figure 1: Graphical description of hypotheses about relationships between KM activities

RESEARCH METHODOLOGY

The research design mainly follows a deductive approach, that begins with an abstract, logical relationship between concepts, then moves toward concrete empirical evidence (Neuman 2003: 51). The purpose of this study is hypothesis testing, which offers enhanced understanding of the relationships between KM activities. A cross-sectional design is used in this study to get a 'snap-shot' of the KM process in construction contracting organisations. The data were gathered over a period of several months. The mail questionnaire was chosen as the data collection method. The questionnaire design includes two (2) major sections. Section 1 elicits respondents' opinions on how well KM activities were being executed by the organisations at the time of the survey. Five-point Likert scales were applied to measure

KM practices. Section 2 gathers demographical information about the respondents and their organisations. The questionnaire was pre-tested with ten (10) contractors in Hong Kong to evaluate the questionnaire for clarity, bias, ambiguous questions, and relevance to the business environment and operations of Hong Kong contractors. Eight (8) respondents offered valid feedback and advice that was considered sufficient for serving the purpose (Burns and Bush 1998). The data collection process began after the questionnaire had been finalised, based on the pre-test feed back.

The research question statements indicate the unit of analysis is at company level. Large- and medium-sized contractors within Hong Kong represent the theoretical population, because they provide a relatively better environment for KM compared with small contractors, whilst are much more arduous in enabling KM practices, compared with other construction organisations, e.g. engineering consulting firms (Ng 2003). The population comprises 260 contractors and includes 109 Group C contractors for public works with contract values exceeding \$50 million, and 125 Group B contractors for public works with contract values of up to \$50 million (ETWB 2005). Some Group A contractors (for public works with contract values of up to HK\$20 million) (ETWB 2005) with reasonable scope as well as the in-house contractors of major developers can also be considered as a part of the population. To select sample candidates, two (2) trade directories were referred to, i.e. the "List of Approved Contractors for Public Works" (ETWB 2005) published through the website of the Environment, Transport and Works Bureau (ETWB) of the Government of the Hong Kong Special Administrative Region; and the "Members List" (HKCA 2005) of the Hong Kong Construction Association (HKCA), whose members represent local and overseas contractors operating in Hong Kong. The sample that was randomly drawn from these two sources covers mainly Group B and Group C contractors.

During the survey process, the contractors were first contacted via e-mail, telephone and networking to confirm contact details and to introduce the survey. The self-administered questionnaire were then mailed or delivered in person to the managerial and professional staff member(s) within these organisations. A cover letter was attached to the questionnaire to introduce the researcher, objectives of the study, and the importance of the survey. A self-addressed, stamped return envelope was also included in the package, and a total of 525 questionnaire packages were delivered. Telephone and e-mail follow up were undertaken within a week subsequent to the delivery of the questionnaire packages, and necessary second mailing took place afterwards. More than 100 second mailing questionnaire packages were delivered. 15 structured interviews were undertaken during the process of survey to provide more perspectives about the phenomena under investigation.

DATA ANALYSIS

To provide statistical support for the research propositions, gathered data were analysed using a number of statistical techniques such as data examination, factor analysis and regression analysis processed through SPSS version 12.0 standard procedures.

SURVEY RESPONSE

Over four (4) months' time, useful responses were provided by 99 organisations, which represents about 38% of the research population. A total of 157 useful responses were received after completion of follow-up mailings. Since the subject matter is the respondents' organisations, measured by the perception of the respondents, no more than five (5) useful feedback questionnaires were chosen from each company to avoid bias in the data. Based on this rule, 149 of 157 response questionnaires were retained for data analysis. Among 149 responses, 66 (44.3%) responses were acquired through networking, whilst 83 (55.7%) were acquired from direct mailing. The responses were considered a good representation of the opinions of the population, since at the time of this survey the majority of the 149 respondents were *middle-aged*: 117 (78.5%) of respondents were over 40 years of age; *well educated*: 123 (82.6%) of respondents held a bachelor degree or higher; *at peak of their career*: 48 (32.2%) were top management, 28 (18.8%) were managers for functional departments, 27 (18.1%) were project managers, project directors and site agents; and 15 (10.1%) were senior professional staff members; *experienced*: 131 (87.9%) of respondents had more than ten (10) years' work experience in the industry, with 77 (51.7%) having worked in the industry for more than 20 years; *knowledgeable about the operations of the companies they were serving*: 101 (67.8%) respondents had worked for their companies for more than five (5) years, among them 66 (44.3%) who had served more than ten (10) years; *from three major groups of contractors in Hong Kong*: 106 (71.1%) of respondents were from local Hong Kong contractors, 34 (22.8%) from branches or subsidiary companies of overseas corporations, 7 (4.7%) from branches or subsidiary companies of state-owned enterprises of the People's Republic of China; and *representing the population in four different sizes of organisations in terms of annual turnover*: 35 (23.5%) were from organisations with an annual turnover of less than HK\$ 100 million; 34 (22.8%) from organisations with an annual turnover of HK\$ 100-500 million; 18 (12.1%) from those with an annual turnover of HK\$ 501-1,000 million; 33 (22.1%) from those with an annual turnover of HK\$ 1,001-5,000 million; and 26 (17.4%) from those with an annual turnover of more than HK\$ 5,000 million.

DATA EXAMINATION

During missing value analysis, six (6) cases were deleted from the data file to keep the maximum proportion of missing values which were identified in six (6) KM activity variables to 1.4%; this is substantially less than the 5% limit (Tabachnick and Fidell 2001: 59). No missing value was identified on the other 35 variables. Therefore, pairwise deletion of missing data procedure was adopted for handling missing values (Pallant 2001; Tabachnick and Fidell 2001:59).

As both correlation and factor analysis are sensitive to outlying cases and robust to assumptions of normality and linearity, data screening techniques were applied to all KM activity variables to assess their distribution (Coakes 2005; Tabachnick and Fidell 2001:588). All variables showed a slight level of skewness (either positively or negatively), which reflects the underlining nature of the constructs being measured. Only two (2) variables' skewness was close to or equal to 1.000. Boxplots identified outliers in the data of

several variables, particularly on those with relatively larger skewness. Given the 5% Trimmed Mean and the original mean for these variables were very similar (the differences being less than 0.09), the identified outlier values for these variables were not too different from the remaining distribution, and cases were retained in the data file (Pallant 2001:62). Histograms of KM activity variables scores appeared to be reasonably normally distributed; and their normal probability plots showed cases falling more or less in straight lines. Thus, the normality of KM variables was reasonably upheld. Linearity was also assumed, since the Scatterplot matrix of the variables presented no nonlinear patterns in the data.

One-way analysis of variance (ANOVA) was applied to identify whether significant differences existed between the opinions evident in responses from different company categories in terms of turnover, and of national background. ANOVA, based on the national background categories, revealed F-probability of significance at 0.05 level on six (6) of 35 KM activity variables, while ANOVA on turnover categories showed only two (2) variables having F-probability of significance at 0.05 level. This indicated the existence of different opinions among the responses of various company categories on a limited number of variables. Given the range values of the group-means of these variables were only around 0.50, this suggests that such differences in the context of social science study were not so significant. None of these variables was removed from the data file, since the data distribution of these variables was not distorted by the different opinions of specific groups. Subsequent to the data examination process, 143 cases remained in the data file for further analysis.

SCALE DEVELOPMENT

Recent empirical studies (Darroch 2003; Gold et al 2001) provide the measurement variables for operationalisation of the four (4) KM activity constructs (Chen and Mohamed 2005; Chen et al 2005). Since the number of scale items was reduced and descriptions modified based on prior studies in the context of the construction industry (Egbu et al 2003b; Kululanga et al 2002), exploratory factor analysis was needed to assess the degree to which the data meet the expected structure. R factor analysis was adopted for identifying the structure among the set of measurement variables for each construct in the model, and also for data reduction. The VARIMAX method for orthogonal rotation under the component factor model was chosen to give a clear separation of the factors (Hair et al 1998: 110). The 143 cases in the data file met the acceptable sample size of 100 for factor analysis; and was much larger than the minimum requirement of 80, that was five (5) times as many subjects as the variables to be analysed in the constructs with the largest number of variables (16) (Hair et al 1998: 98).

As Table 1 presents, the factor analysis identified four (4) factors for the construct of '*knowledge acquisition*': 'acquisition of knowledge through training', 'financial knowledge acquisition', 'market knowledge acquisition', and 'acquisition of knowledge about business operations'; two (2) factors for the construct of '*knowledge dissemination*': 'tacit knowledge dissemination' and 'explicit knowledge dissemination'; two (2) factors for that of '*responsiveness to knowledge*': 'response to market knowledge' and 'response to knowledge about clients; and one (1) factor for '*knowledge application*'. Further factor analysis was subsequently applied to the variables of each identified factor to confirm the single dimension of data, and to assess its reliability so as to create a summated scale for the

concept represented by each factor.

In most of factor analysis attempts (11 out of 12) performed in this study, the Kaiser-Meyer-Olkin (KMO) measure of sampling adequacy were greater than 0.60, ranging from 0.670 to 0.848. Bartlett's tests of sphericity were large and significant at 0.00 level. All anti-image correlation values ranged from 0.624 to 0.913, well above the acceptable level of 0.5 (Hair et al 1998: 99). The factorability was hence upheld for these 11 factor analysis scenarios (Coakes 2005). The only exceptional case was the factor analysis for the factor of 'acquisition of knowledge through training', which presented a KMO value of 0.50, slightly lower than the threshold of 0.60. Nevertheless, given its anti-image correlation (valued at 0.50) and that its Bartlett's test of sphericity was significant at 0.00 level, factorability was assumed for this factor analysis.

With the sample of 143, a factor loading of 0.50 and above was considered significant at 0.05 level to obtain a power level of 80% (Hair et al 1998:112). As illustrated in Table 1, the cumulative percentage of total variance extracted by successive factors for all 12 factors analysis were over 50%; The reliability coefficient of all measures was above the low limit of 0.70, indicating satisfactory consistency of the scales for the constructs and their factors (Hair et al 1998:118). Since the constructs were conceptually defined based on a combination of the literature review, previous empirical studies, and the pilot study these KM activity scales were considered to have face validity (Neuman 2003:183), and they do measure the key practices of KM activities performed within the research context. These scales' nomological validity was confirmed by regression analysis, which is outlined in the following section (Hair et al 1998:118; Samson and Terziovski 1999).

Table 1: Results of Factor Analysis

Contrusts and Factors	No of Variables	Cronbach's Alpha	Total Variance Explained (%)
Knowledge Acquisition (4)	14	0.877	65.8
1. Acquisition of knowledge through training	2	0.705	77.7
2. Financial knowledge acquisition	3	0.810	73.0
3. Market knowledge acquisition	4	0.790	62.2
4. Acquisition of knowledge about business operations	5	0.791	54.5
Knowledge Dissemination (2)	9	0.862	60.2
1. Tacit knowledge dissemination	5	0.828	59.2
2. Explicit knowledge dissemination	4	0.772	59.7
Responsiveness to Knowledge (2)	9	0.886	68.3
1. Response to market knowledge	5	0.868	65.8
2. Response to knowledge about clients	4	0.858	70.1
Knowledge Application (1)	5	0.868	65.5

RELATIONSHIP IDENTIFICATION

Correlation analysis and simple and multiple regression analysis were employed in analysing the relationships between the constructs in the conceptual model. Correlation analysis showed that the four (4) KM activity constructs were positively associated with one another, as were their factors. Pearson correlation r (coefficient of correlation) values between the four constructs ranged from 0.538 to 0.762, and those between the factors from 0.284 to 0.776. All of these r values were significant at 0.01 level.

Stepwise regression analysis was subsequently employed to depict how a specific KM activity being predicted by the other three constructs; and to reveal the most active factor within each construct that can be used to predict the largest number of the factors under the other KM constructs. During the stepwise analysis, the predictor having largest correlation r with the dependent variable was input into the regression model at first, followed by the variable with the second largest r . The one with third largest r was the last to be input.

The simplest regression model of smallest S^2 (the mean square error), largest adjusted R^2 (the multiple coefficient of determination), both F test for the overall model, and t tests for the population correlation coefficient significant at 0.01 level (Bowerman et al 1986), was selected to predict each KM activity. In the analysis of the nine (9) factors, given the R^2 increase caused by the third predictor was less than 5%, the two (2) predictors contributed most to R^2 were kept in the model, whilst the optional third predictors were tested during the model selection process.

The 143 cases in the data file satisfied the minimum sample size of 120 for supporting the case-to-IV ratio of 40 to 1 required by stepwise regression analysis with three (3) independent variables (IVs) (Tabachnick and Fidell 2001:117). Multicollinearity was absent from these selected models where tolerance values were around 0.5 (> 0.1) and the variance inflation factor (VIF) around 2.0. Mahalanobis distance values indicated that at the 0.01 level, there were no multi-variate outliers among independent variables; normal probability plot suggested no major deviations from normality; and scatter plot of residuals presented no nonlinear pattern or pattern of increasing or decreasing residuals, thereby meeting the assumption of linearity, homoscedasticity and independence of residuals (Hair et al 1998; Pallant 2001). Durbin-Watson values of more than 1.70 (> 1.50 , at 0.01 level) showed no evidence of autocorrelation among the residuals (Berenson and Levine 1996:745).

The regression analysis revealed that about 65% of the activity level of 'knowledge dissemination' can be predicted and explained by the combination of those of 'knowledge acquisition' and 'knowledge application'. The regression models for the other three KM activities are illustrated in Figure 1. The analysis also identified the four (4) most active KM activity factors, i.e. 'acquisition of knowledge about business operations', 'tacit knowledge dissemination', 'response to market knowledge', and 'knowledge application', which can be used to predict the level of three (3) activities under the KM constructs other than the one they belong to. The most passive KM activity factor was 'acquisition of knowledge through training', which appears to play no role in predicting other factors with statistical significance. The interviews revealed that the contractors faced a challenge of dynamic organisational structure, where employees were constantly changing with project delivery cycle. Return on the investment in the formal training such as university courses and

conferences was a concern for the organisations, particularly during economic down-turn such as the one Hong Kong construction industry had seen in recent years. Figure 1 depicts the relationships demonstrated by regression models selected for KM activity constructs. Figure 2 presents the process of identifying both the most and the least active KM activity factors.

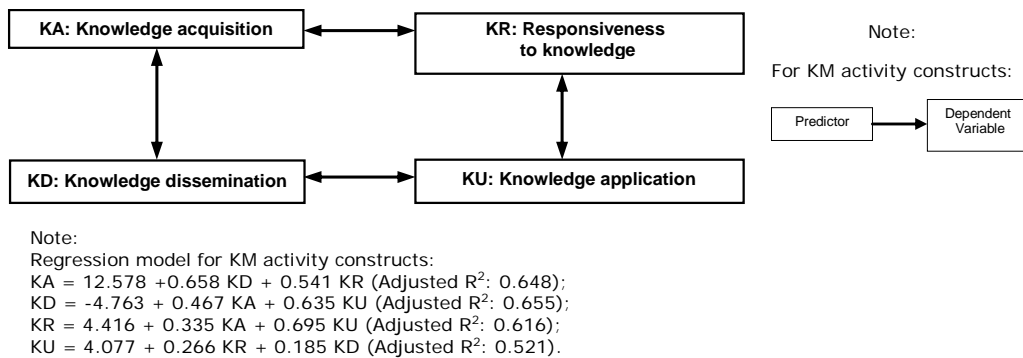

Figure 1: The Relationships between KM Activity Constructs Demonstrated by the Regression Models

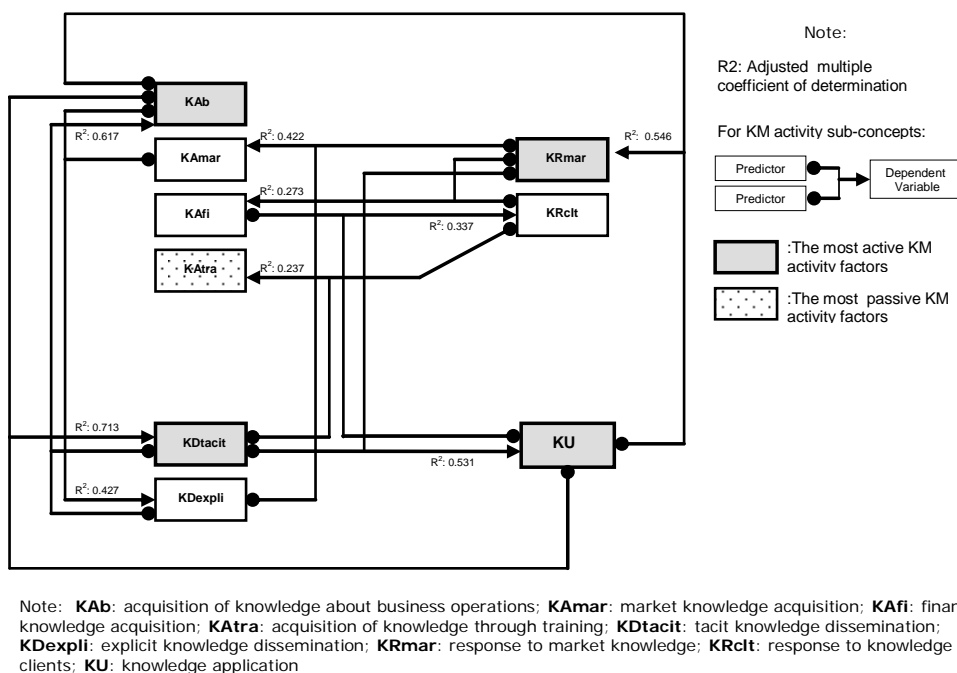

Figure 2: The Relationships between KM Activity Factors Demonstrated by the Regression Models and the Most and the Least Active KM Activity Factors

CONCLUSION

The empirical study reported herein reveals that the interactions between different categories of KM activities in construction organisations operating in Hong Kong are in line with the theoretical propositions supported by the literature review. Knowledge acquisition and application play paramount roles in the development of the organisational knowledge asset; the higher level of these two (2) types of activities creates a larger knowledge pool that demands greater knowledge dissemination capacity and also enables more active response to the knowledge in both the internal and external environment (Nonaka and Takeuchi 1995). Meanwhile, the greater dissemination capacity and more vigorous response to knowledge facilitate and stimulate acquisition and application of knowledge (Gold et al 2001).

Some essential aspects of the intricate interactions were highlighted by the paper's further scrutiny of specific KM activities. Acquisition of knowledge about business operations affects the level of knowledge dissemination, particularly the tacit knowledge dissemination. The tacit and context-specific nature of the project-related knowledge in the industry (Kamara et al 2002) decides the essential roles of tacit knowledge dissemination procedures such as project review, mentoring and coaching, analysis of - and discussion on - market information. The extent to which the tacit knowledge is externalised and distributed within the organisation influences that organisation's approach to applying the knowledge and reacting to the market, whilst vigorous knowledge application leads to an active response to market and to the needs of clients. This in turn enables a higher level of acquisition of market and financial knowledge.

REFERENCES

- Abou-Zeid, E.-S. (2002). "A Knowledge Management Reference Model." *J. of Knowledge Management*, 6 (5) 486-499.
- Berenson, M. L., and Levine, D. M. (1996). *Basic Business Statistics, Concept and Applications*, Sixth Edition, Prentice-Hall International, Inc., London.
- Bowerman, B. L., O'Connell, R. T., and Dickey, D. A. (1986). *Linear Statistical Models*, Duxbury Press, Boston.
- Burns, A. C., and Bush, R. F. (1998). *Marketing Research*, Prentice Hall, New Jersey.
- Cavaleri, S. A. (2004). "Leveraging Organisational Learning for Knowledge and Performance." *The Learning Organisation*, 11 (2) 159-176.
- Chen, L., and Mohamed, S. (2005). "Modelling the Contribution of Knowledge Management Towards Achieving Organisational Business Objectives", *1st International Conference on Construction Engineering and Management*, Seoul, Korea, 714-718.
- Chen, L., Mohamed, S., and Chan, E. M. Y. (2005). "Knowledge Management Practices in Construction: Evidence from Hong Kong", *CIB W102-2005 Meeting and International Conference: Information and Knowledge Management in a Global Economy: Challenges and Opportunities for Construction Organizations*, Lisbon, Portugal, 435-443.
- Coakes, S. J. (2005). *SPSS: Analysis without Anguish: Version 12.0 for Windows*, John Wiley & Son Australia, Ltd.
- Darroch, J. (2003). "Developing a Measure of Knowledge Management Behaviors and Practices." *J. of Knowledge Management*, 7 (5) 41-54.

- Diakoulakis, I. E., Georgopoulos, N. B., Koulouriotis, D. E., and Emiris, D. M. (2004). "Towards a Holistic Knowledge Management Model." *J. of Knowledge Management*, 8 (1) 32-46.
- Egbu, C., Anumba, C., Quintas, P., Hutchinson, V., Hayles, C., and Ruikar, K.(2003a). Knowledge Production, Sources & Capabilities in the Construction Industry, (available at <http://www.knowledgemanagement.uk.net>).
- Egbu, C., Anumba, C., Quintas, P., Hutchinson, V., Hayles, C., and Ruikar, K.(2003b). Techniques & Technologies for Knowlwdge Management, (available at <http://www.knowledgemanagement.uk.net>).
- ETWB.(2005). List of Approved Contractors for Public Works, (available at http://www.etwb.gov.hk/consultants_and_contractors/contractors).
- Gold, A. H., Malhotra, A., and Segars, A. H. (2001). "Knowledge Management: An Organizational Capabilities Perspective." *J. of Management Information System*, 18 (1) 185-214.
- Hair, J. F., Anderson, R. E., Tatham, R. L., and Black, W. C. (1998). *Multivariate Data Analysis*, Fifth Edition, Prentice-Hall International, Inc.
- HKCA.(2005). Hong Kong Construction Association Members List, (available at http://www.hkca.com.hk/new/pg_hkca_member.htm).
- Kalling, T. (2003). "Knowledge Management and the Occasional Links with Performance." *J. of Knowledge Management*, 7 (3) 67-81.
- Kamara, J. M., Augenbroe, G., Anumba, C. J., and Carrillo, P. M. (2002). "Knowledge Management in the Architecture, Engineering and Construction Industry." *Construction Innovation*, 2 (3) 53-67.
- Kululanga, G. K., Price, A. D. F., and McCaffer, R. (2002). "Empirical Investigation of Construction Contractors' Organizational Learning." *J. of Constr. Engrg. and Mgmt.*, 128 (5) 385-391.
- McCann, J. E., and Buckner, M. (2004). "Strategically Integrating Knowledge Management Initiatives." *J. of Knowledge Management*, 8 (1) 47-63.
- Neuman, W. L. (2003). *Social Research Methods: Qualitative and Quantitative Approaches*, Fifth Edition, Allyn and Bacon.
- Ng, K. H. (2003). "Application of Knowledge Management in Hong Kong Construction Industry", M.Sc. thesis, City University of Hong Kong, Hong Kong.
- Nonaka, I., and Takeuchi, H. (1995). *The Knowledge Creating Company*, Oxford University Press, New York.
- Pallant, J. (2001). *Spss Survival Manual : A Step by Step Guide to Data Analysis Using Spss for Windows (Version 10)*, Allen & Unwin, St Leonards, N.S.W.
- Samson, D., and Terziovski, M. (1999). "The Relationship between Total Quality Management Practices and Operational Performance." *J. of Operations Management*, 17 (4) 393-409.
- Shankar, R., Singh, M. D., Gupta, A., and Narain, R. (2003). "Strategic Planning for Knowledge Management Implementation in Engineering Firms." *Work Study*, 52 (4) 190-200.
- Tabachnick, B. G., and Fidell, L. S. (2001). *Using Multivariate Statistics*, Fourth Edition, Allyn and Bacon.