TILT-UP DESIGN SOFTWARE VERIFICATION FOR LIGHTWEIGHT CONCRETE WALL BEHAVIOR DURING LIFTING

Adel Alsaffar, Ph.D. , dr.alsaffar@gmail.com

Nawari O. Nawari, Assistant Professor, nnawari@ufl.edu

School of Architecture, University of Florida, Gainesville, FL, USA

Larry Muszynski, Associate Professor, larrym@ufl.edu

Rinker School of Building Construction, University of Florida, Gainesville, FL, USA

ABSTRACT

Tilt-up construction is one of the increasingly growing construction methods in the world. In 2007, approximately 790 million square feet of tilt-up buildings were constructed based on a survey conducted by the Tilt-Up Concrete Association (TCA 2011).

Many computer software packages are capable of designing the tilt-up walls as an element in a structure or a building subjected to normal loading conditions. However, only a few of computer programs can design the tilt-up wall for lifting stresses. In this study, a model scale tilt-up wall (10 feet by 9 feet) was constructed using a lightweight concrete with surface mount strain gages in order to examine the strains and stresses of the panel during lifting. The measured strains and stresses were compared to those obtained from statics computations and two commercial software programs. Recommendations are made based on these results for utilizing these software packages for analyzing and designing lightweight concrete tilt-up walls when subjected to lifting forces.

Keywords: Tilt-up walls, lightweight concrete, lifting stresses, lifting strains.

1. INTRODUCTION

Lightweight concrete can be dated back to over 2000 years ago. The lightweight concrete structures were used during the early Roman Empire. It has many advantages over normal weight concrete such as internal curing, fire resistance, thermal insulation in addition to the lighter density. Combining the benefits of the tilt-up construction method and the advantages of the lightweight concrete result in many benefits such as a better performance and quality, smaller sections for the super- and sub-structural elements, and overall lighter weight.

Research on lightweight concrete tilt-up walls in general is very scarce. Specifically speaking, investigation of lightweight concrete tilt-up walls during lifting is not found. Thus, the main scope of this project is to investigate the strength and behavior of the lightweight concrete tilt-up panels during lifting and compare the results with those obtained from commercially available software design tools.

2. TILT-UP WALL STRESSES DURING LIFTING

Concrete is normally characterized by its 28th day compressive strength such as 4,000 or 5,000 psi concrete. Although the compressive strength is important for any tilt-up construction project, the early age strength of the concrete is vital. The tilt-up wall must gain sufficient strength at early age to facilitate lifting after a few days from casting.

ACI committee 551 requires a 28-day minimum compressive strength of 3,000 psi. Nevertheless, the lifting insert manufacturers call for a compressive strength of 2,500 psi at the day of lift. Therefore, a higher 28-day strength is commonly specified to lift the panels as fast as possible. Another factor affecting the lifting of the panels is the flexural strength of the concrete; 28-day modulus of rupture of 550 psi is recommended to avoid flexural cracking. Lifting inserts manufacturers ask for modulus of rupture of 400 to 500 psi if the bending stresses are below 250 psi.

Consequently, a concrete mixture is proportioned for early compressive and flexural strength gain. For example, cementitious materials such as fly ash and slag slow the rate of early strength gain and can disturb panel finishing. Also, air entraining agents reduce the strength of the concrete leading to cracking, particularly during the lifting operation. (ACI.551 2010)

Structural lightweight concrete number H65BC from Florida Rock Industries in Gainesville was found suitable for this research. Table 1 below describes the mix design of the lightweight concrete used in this project.

Table 1: Mix Design for structural lightweight concrete (H65BC)

Material	ASTM	TYPE	Quantity	
Cement	C 150	II	650	Lbs
Water	--		250	Lbs
Fine Aggregate	C 33	Sand	1130	Lbs
Aggregate	C 330	#7LTWT	1075	Lbs
Air Entrained	C 260	AEA-92S	3.0	oz
Water Reducer	C494	EUCON WR	55	oz
W/C Ratio			0.39	
Slump (in)			5 ±1"	
Air Content (%)			4.5 ±1.5%	
Plastic Unit Weight (lbs/cf)			115.1 ±1.5	

Materials per Cubic Yard

2.1 Angle of Inclination

The tilt-up panel was considered as a simply supported beam with the maximum moment at mid span

$$M(\max) = \frac{WL^2}{8}$$

Where:

W = Self-weight of the panel

L = Length of the panel

For Tilt-up panel, "θ" is the angle of inclination between the tilt-up panel and the casting surface as the panel being lifted.

The maximum moment was calculated with the angle of inclination "θ" as follows:

$$M = \frac{W}{\cos\theta} \times \frac{(L \cos \theta)^2}{8}$$

The maximum moment occurs when $\cos \theta$ equals to 1, that is when θ equals to 0. This indicates that the maximum moment occurs when the tilt-up panel is flat on the ground (Figure 1).

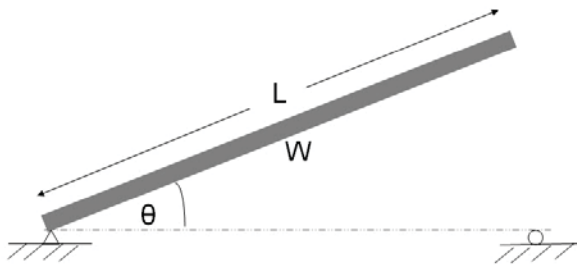

Figure 1: Angle of inclination

2.2 Statics Computations

Statics calculations were performed to determine the maximum positive and negative moment due to lifting. Based on these maximum values of moments, strain gauges were mounted to monitor the change in lengths.

2.2.1 Moment Computations in the Y-Y Direction

The tilt-up panel was divided into three sections (Figure 2) to calculate the weight of each section of the panel. The weight the sections were used to calculate the Maximum moments of the panel at zero degree.

The Unit Weight of concrete used in these calculations is 117 lbs/ft³ which was the wet unit weight of the lightweight concrete in the experimental batch:

W1 = Weight of section 1; W2= Weight of section 2; W3= Weight of section 3

$$W1 = 10\text{ft} \times 3.5\text{in} \times \frac{1\text{ft/in}}{12} \times 117\text{ pcf} = 341.25\text{ lb/ft}; \quad W2 = 6\text{ft} \times 3.5\text{in} \times \frac{1\text{ft/in}}{12} \times 117\text{ pcf} = 204.75\text{ lb/ft}$$

$$W3 = 10\text{ft} \times 3.5\text{in} \times \frac{1\text{ft/in}}{12} \times 117\text{ pcf} = 341.25\text{ lb/ft}$$

The shear and moment diagrams for the tilt-up panel in the Y-Y direction are illustrated in (Figure 3). Figure 4 depicts a maximum bending moment of 1094.8 lb-ft.

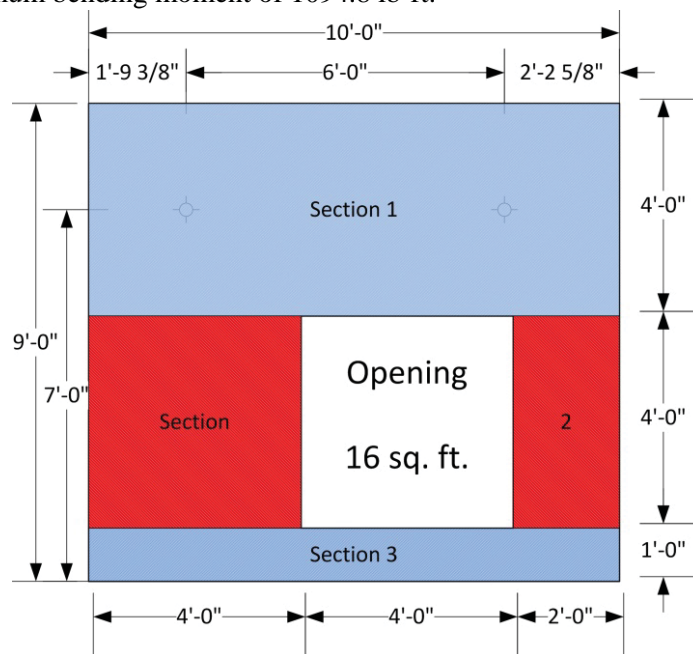

Figure 2: Tilt-up panel sections to calculate moments in Y-Y direction

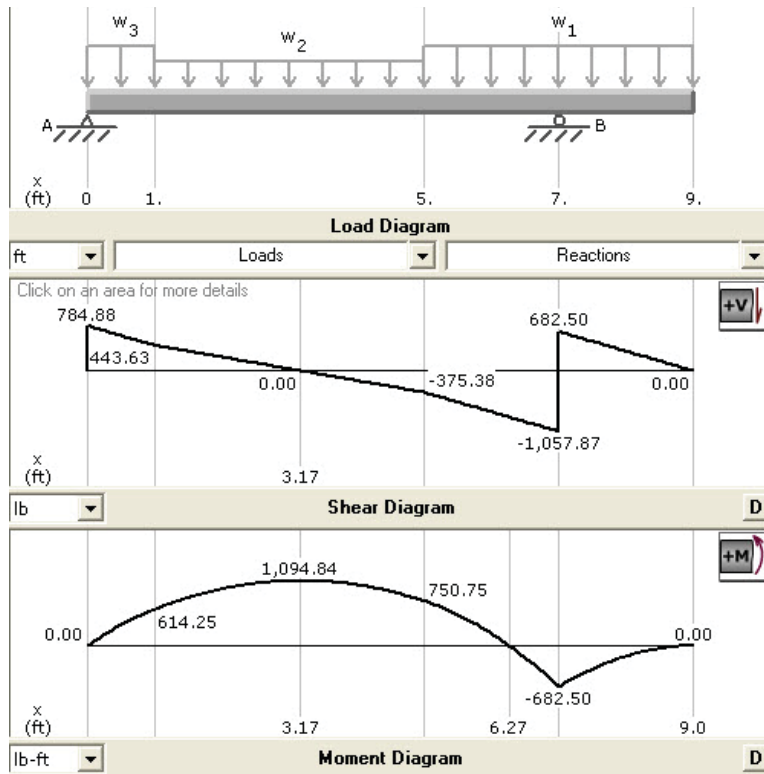

Figure 3: Shear and moment diagrams of tilt-up panel at zero degree in Y-Y direction

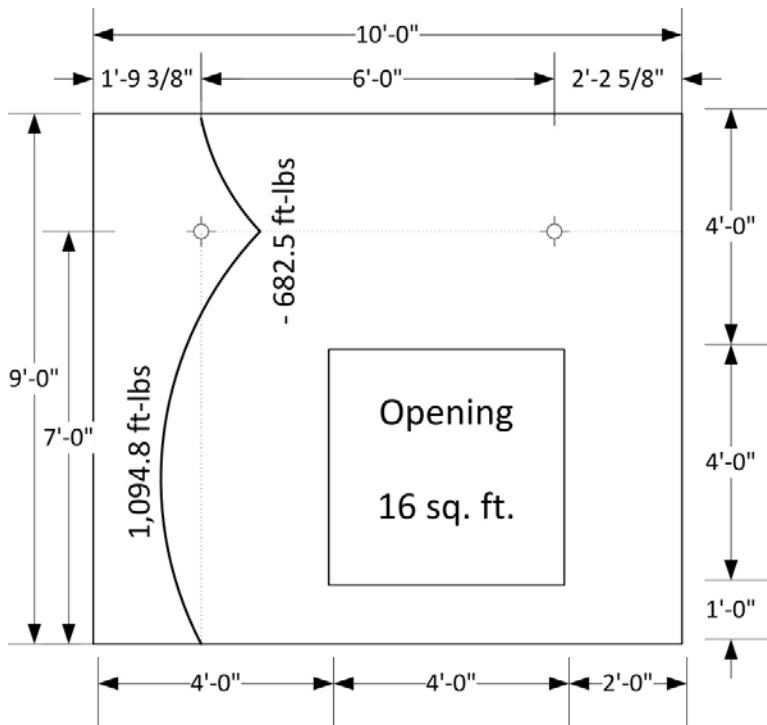

Figure 4: Maximum moments Y-Y direction, at zero degree due to lifting

2.2.2 Stresses Computations in the Y-Y Direction

The stresses in the Y-Y direction were calculated for the maximum moment at 3.17 feet from the panel's bottom according to the following equation:

$$S_b = \frac{M}{S_x}$$

Where:

S_b = Bending Stress (psi)

M = Bending Moment (in-lb)

S_x = Section Modulus (in³)

The section modulus is determined using the following equation

$$S_x = \frac{bd^2}{6}$$

Where:

S_x = Section Modulus (in³)

b = width of the section studied (in)

d = Thickness of the panel (in)

$$S_x = \frac{(10\text{ft} - 4\text{ft}) \times 12\text{ (in/ft)} \times (3.5\text{in})^2}{6} = 147\text{ in}^3$$

$$S_b = M / S_x = \frac{1,094.8\text{ lb-ft} \times 12\text{(in/ft)}}{147\text{ in}^3} = 89.7\text{ psi @ 3.17}$$

On the other hand, the stresses at 7 ft were calculated as follows:

$$S_x = \frac{bd^2}{6} = \frac{(10\text{ft}) \times 12\text{ (in/ft)} \times (3.5\text{in})^2}{6} = 245\text{ in}^3$$

$$S_b = M / S_x = \frac{682.5\text{ lb-ft} \times 12\text{(in/ft)}}{245\text{ in}^3} = 33.4\text{ psi @ 7 ft.}$$

2.2.3 Moment Computations in the X-X Direction

The tilt-up panel was divided into three sections as shown in Figure 2 to calculate the weight of each section of the panel. The weight the sections were used to compute the maximum bending moments of the panel at zero degree. The weight of the panel was divided into two sections along the zero shear point (3.17 ft from the bottom).

The Unit Weight of the lightweight concrete is 117 lb/ft³.

W_1 = Weight of section 1; W_2 = Weight of section 2; W_3 = Weight of section 3

$$W_1 = (9\text{ft} - 3.17) \times 3.5\text{in} \times \frac{1\text{ ft/in}}{12} \times 117\text{ pcf} = 199\text{ lb/ft}$$

$$W_2 = 4\text{ft} \times 3.5\text{in} \times \frac{1\text{ ft/in}}{12} \times 117\text{ pcf} = 136.5\text{ lb/ft}$$

$$W_3 = (9\text{ft} - 3.17\text{ft}) \times 3.5\text{in} \times \frac{1\text{ ft/in}}{12} \times 117\text{ pcf} = 199\text{ lb/ft}$$

Figure 5, shows the shear and moment diagrams for the tilt-up panel in the X-X direction. The P1 and P2 are the vertical tension values of the lifting inserts of 870.2 lb. as calculated earlier. Figure 6, shows a maximum negative moment of 488.9 ft-lb. at the right insert. It also shows a maximum positive value of 300.1 lb-ft. at 4.38 feet from the left edge of the panel. The left insert has a negative moment value of 315.3 ft-lb.

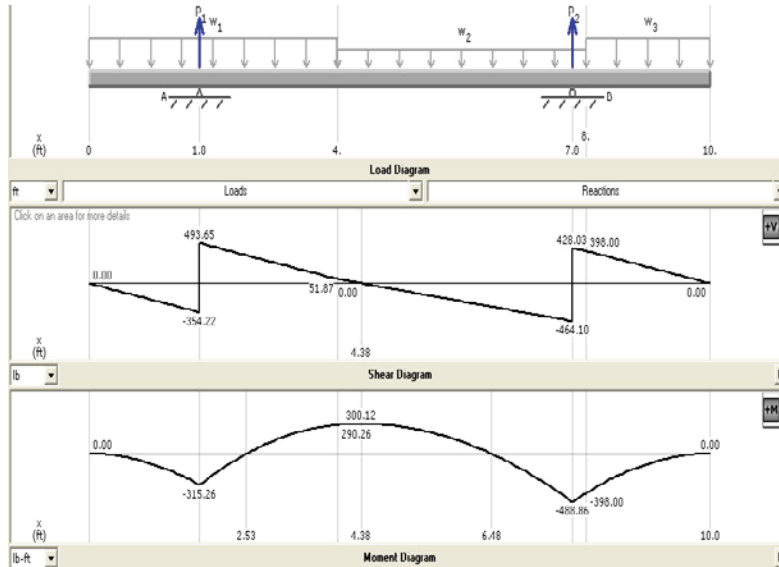

Figure 5: Shear and moment diagrams of tilt-up panel at zero degree in Y-Y direction

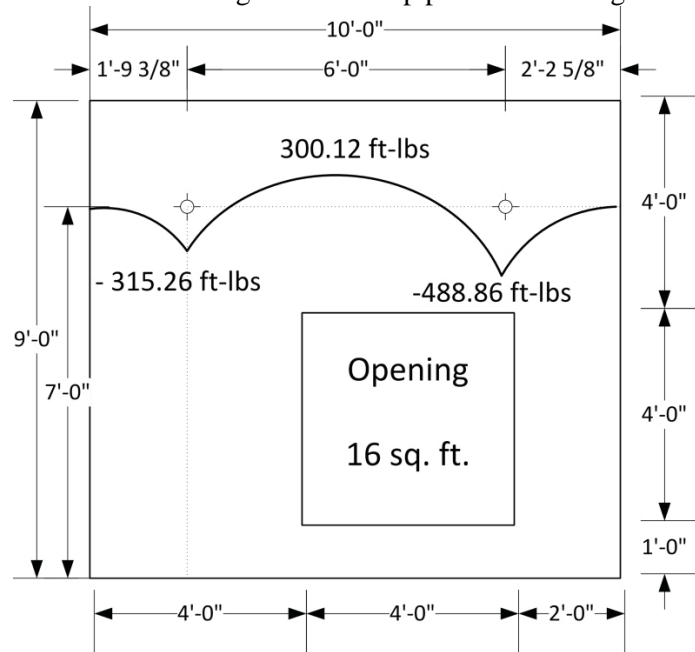

Figure 6: Maximum moments X-X direction, at zero degree due to lifting

2.2.4 Stresses Calculations in the X-X Direction

Stresses at the lift and right inserts were the highest due to the maximum negative bending moments. On the other hand, stresses occurred along the inserts axis, 4.38 ft from the left edge of the panel due to the maximum positive bending moment. The stresses were calculated as follows:

The stress at the right insert:

$$S_b = M / S_x = \frac{488.9 \text{ lb-ft} \times 12(\text{in/ft})}{4 \text{ ft} \times 12(\text{in/ft}) \times 3.5^2 / 6} = 59.9 \text{ psi}$$

The stress at the left insert:

$$S_b = M / S_x = \frac{315.3 \text{ lb-ft} \times 12(\text{in/ft})}{(9-3.17) \text{ ft} \times 12(\text{in/ft}) \times 3.5^2 / 6} = 56.3 \text{ psi}$$

The stress at 4.38 ft from the left edge:

$$S_b = M / S_x = \frac{300.1 \text{ lb-ft} \times 12(\text{in/ft})}{4 \text{ ft} \times 12(\text{in/ft}) \times 3.5^2 / 6} = 36.8 \text{ psi}$$

2.3 Statics Computations Using 1.5 Suction Factor

Same concepts of the statics calculations were applied using a 1.5 suction factor to the weight of the panel.

2.3.1 Moment Computations in the Y-Y Direction with Suction

The panel was divided into three sections (Figure) and the weight of each section is shown below.

$$W_1 = (10\text{ft} \times 3.5\text{in} \times \frac{1 \text{ ft/in}}{12} \times 117 \text{ pcf}) \times 1.5 = 512 \text{ lb/ft}$$

$$W_2 = (6\text{ft} \times 3.5\text{in} \times \frac{1 \text{ ft/in}}{12} \times 117 \text{ pcf}) \times 1.5 = 312 \text{ lb/ft}$$

$$W_3 = (10\text{ft} \times 3.5\text{in} \times \frac{1 \text{ ft/in}}{12} \times 117 \text{ pcf}) \times 1.5 = 512 \text{ lb/ft}$$

The maximum positive moment of 1,666 lb-ft occurred at 3.17 feet from the bottom of the panel. The maximum negative moment of 1,024 occurred at 7 feet where the inserts are located (Figure 7).

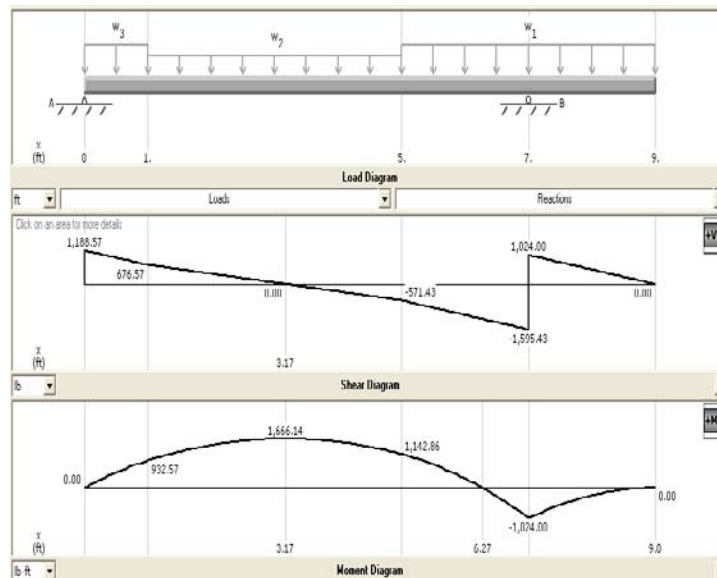

Figure 7: Shear and moment diagram, Y-Y direction with suction

2.3.2 Stresses Computations in the Y-Y Direction with Suction

According to the maximum moments in the Y-Y direction, the following stresses can be calculated:

$$S_b = M / S_x = \frac{1,666 \text{ lb-ft} \times 12(\text{in/ft})}{147 \text{ in}^3} = 136 \text{ psi @ 3.17 ft.}$$

$$S_b = M / S_x = \frac{1,024 \text{ lb-ft} \times 12(\text{in/ft})}{245^3} = 50.1 \text{ psi @ 7 ft.}$$

2.3.3 Moment Computations in the X-X Direction with Suction

The panel was divided into three regions. The weight of each region is calculated with a 1.5 suction factor below.

$$W_1 = ((9\text{ft}-3.17) \times 3.5\text{in} \times \frac{1 \text{ ft/in}}{12} \times 117 \text{ pcf}) \times 1.5 = 298.5 \text{ lb/ft};$$

$$W_2 = (4\text{ft} \times 3.5\text{in} \times \frac{1 \text{ ft/in}}{12} \times 117 \text{ pcf}) \times 1.5 = 205 \text{ lb/ft}$$

$$W_3 = ((9\text{ft}-3.17\text{ft}) \times 3.5\text{in} \times \frac{1 \text{ ft/in}}{12} \times 117\text{pcf}) \times 1.5 = 298.5 \text{ lb/ft}$$

In addition to the weight of the panel, 1,310 lbs. of upward force was applied to the panel during lifting at each insert.

The moment at the right insert was found to be negative 733.3 lb-ft. The maximum positive moment occurred at 4.38 ft from the left with a value of 450.9 lb-ft. The left insert had a negative moment of 472.9 lb-ft (Figure 8).

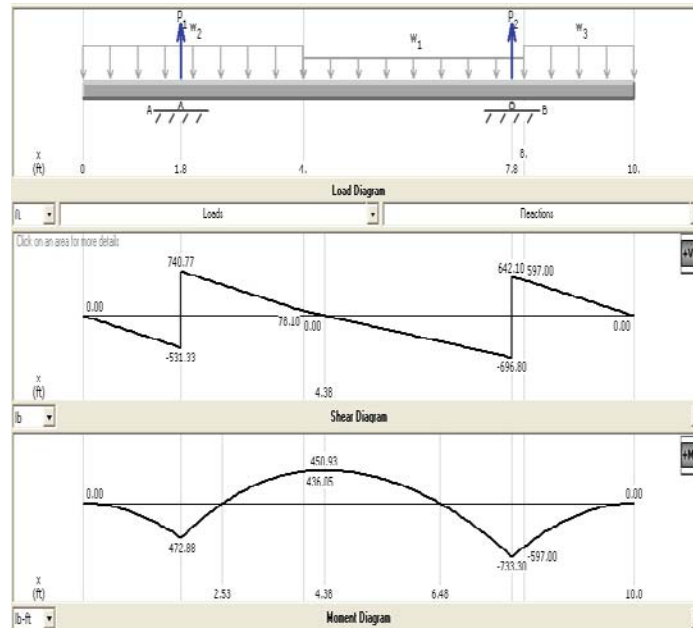

Figure 8: Shear and moment diagrams, X-X direction with suction.

2.3.4 Stresses Calculations in the X-X Direction with Suction

The maximum positive/ negative moments were applied to calculate the stresses as shown below:
The stress at the right insert:

$$S_b = M/ S_x = \frac{733.3 \text{ lb-ft} \times 12(\text{in/ft})}{4\text{ft} \times 12(\text{in/ft}) \times 3.5^2/ 6} = 89.8 \text{ psi}$$

The stress at the left insert:

$$S_b = M/ S_x = \frac{472.9 \text{ lb-ft} \times 12(\text{in/ft})}{(9-3.17) \text{ ft} \times 12(\text{in/ft}) \times 3.5^2/ 6} = 84.4 \text{ psi}; \text{ The stress at 4.38 ft from the left edge}$$

$$S_b = M/ S_x = \frac{450.9 \text{ lb-ft} \times 12(\text{in/ft})}{4\text{ft} \times 12(\text{in/ft}) \times 3.5^2/ 6} = 55.2 \text{ psi}$$

2.4 Stresses from Software Programs

Two of the top leading lifting inserts manufacturers designed the tilt-up wall panel for lifting stresses using their software packages. Their software programs yielded different analysis of the stresses despite the fact that the input is the same. The results are further discussed and compared with the statically calculated stresses and the measured stresses.

2.5 Actual Stresses

Surface mount strain gauges were strategically fixed where the maximum positive/negative moments are expected based on the design calculations. A total of eight gauges were installed to monitor the strains that the concrete undergoes as the tilt-up panel was being lifted. Five of them were vertically fixed in the direction of the Y-axis and three horizontally in the X-axis direction. Figure 9, shows the location of the strain gauges.

The strains collected during lifting operation (Figure 10) were converted to stresses using the modulus of elasticity of the lightweight concrete.

Table 2 lists the stresses of the lightweight concrete tilt-up panel calculated from the surface mount strain gauges, calculated stresses with and without suction, and stress determined by commercial software 1 and commercial software 2. Figure 11 compares stresses obtained through the different means. From figure 11, it can be noted that the results obtained from software packages under estimate the actual stressed during lifting.

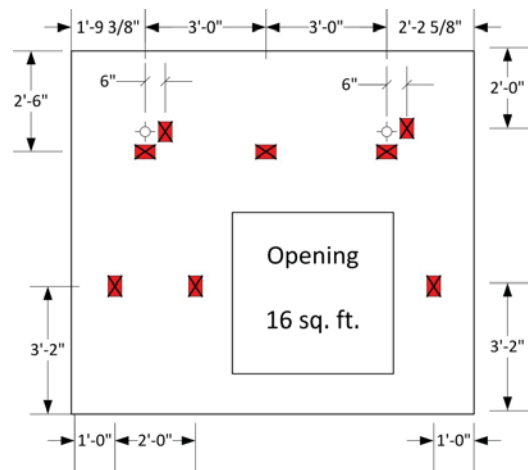

Figure 9: Strain gauges locations.

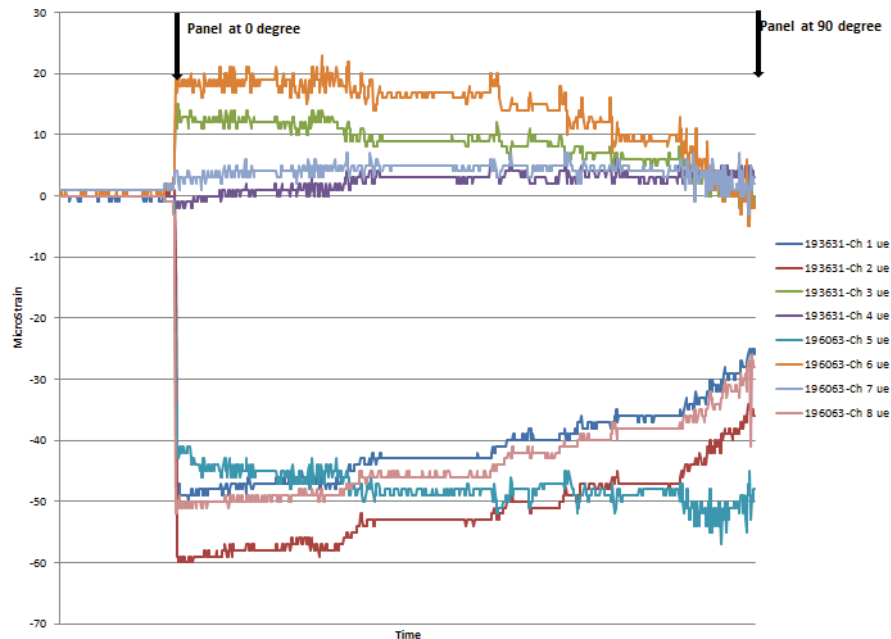

Figure 10: Strain measurements during tilt-up panel lifting

Table 2: Stress comparison of lightweight concrete tilt-up panel

Strain Gauge No.	Measured stresses (psi)	Calculated stresses – no suction (psi)	Calculated stresses – suction (psi)	Commercial Software 1 (psi)	Commercial Software 2 (psi)
1	133.7	89.7	136.0	112.0	88.2
2	143.6	89.7	136.0	112.0	88.2
3	34.7	38.6	57.9	24.0	26.9
4	17.3	56.3	84.4	45.0	32.8
5	106.4	36.8	55.2	44.0	25.2
6	47.0	59.9	89.8	50.0	56.3
7	24.8	33.4	50.1	45.0	32.8
8	128.7	89.7	136.0	112.0	88.2

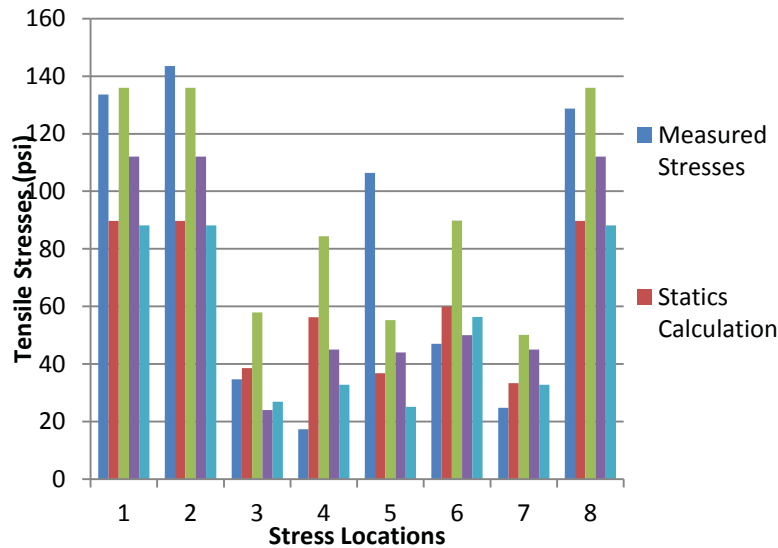

Figure 11: Tilt-up panel stresses during lifting using different methods.

3. CONCLUSION AND FUTURE WORK

This paper investigates the structural behavior of the lightweight concrete tilt-up wall during lifting. Results from the experimental work are compared with the results determined by two commercial software applications. Both computer software tools fell short in predicting the stresses and strains due to lifting where the statically computed stresses with a suction factor of 50% gave a good approximations of the behavior of the tilt-up wall during lifting. Further studies are required to better understand the suction developed at the break off point at zero degree inclination to be able to incorporate its effect into the software applications.

REFERENCES

- Alsaffar, A. (2012). Erection stresses in reinforced concrete tilt-up wall panels. Ph.d. thesis, College of Design, Construction and Planning, University of Florida.
- ACI.213 (2003). Guide for Structural Lightweight-Aggregate Concrete. Detroit, MI, American Concrete Institute. ACI 213R03.
- ACI.551 (2010). Design Guide for Tilt-Up Concrete Panels. Farmington Hills, MI, American Concrete Institute. ACI 551.2R-10.
- TCA (2011). The Architecture of Tilt-up. Mount Vernon, IA, Tilt-up Concrete Association.